

THIS DRAWING IS UNPUBLISHED. RELEASED FOR PUBLICATION ,19 .  
© COPYRIGHT 19 BY AMP INCORPORATED. ALL INTERNATIONAL RIGHTS RESERVED.

LOC		DIST		P		F		ZONE		LTR		REVISIONS		DATE	APPD
CH	11											D	ECN 95033001	30/MAR/95	CMS

1. RETROFIT CONTACT FOR METRIMATE AND AMPLIMITE POWER CONTACT.
2. WIRE BARREL WILL ACCEPT #8 AWG WIRE.
3. MATES WITH PN 193457-1.

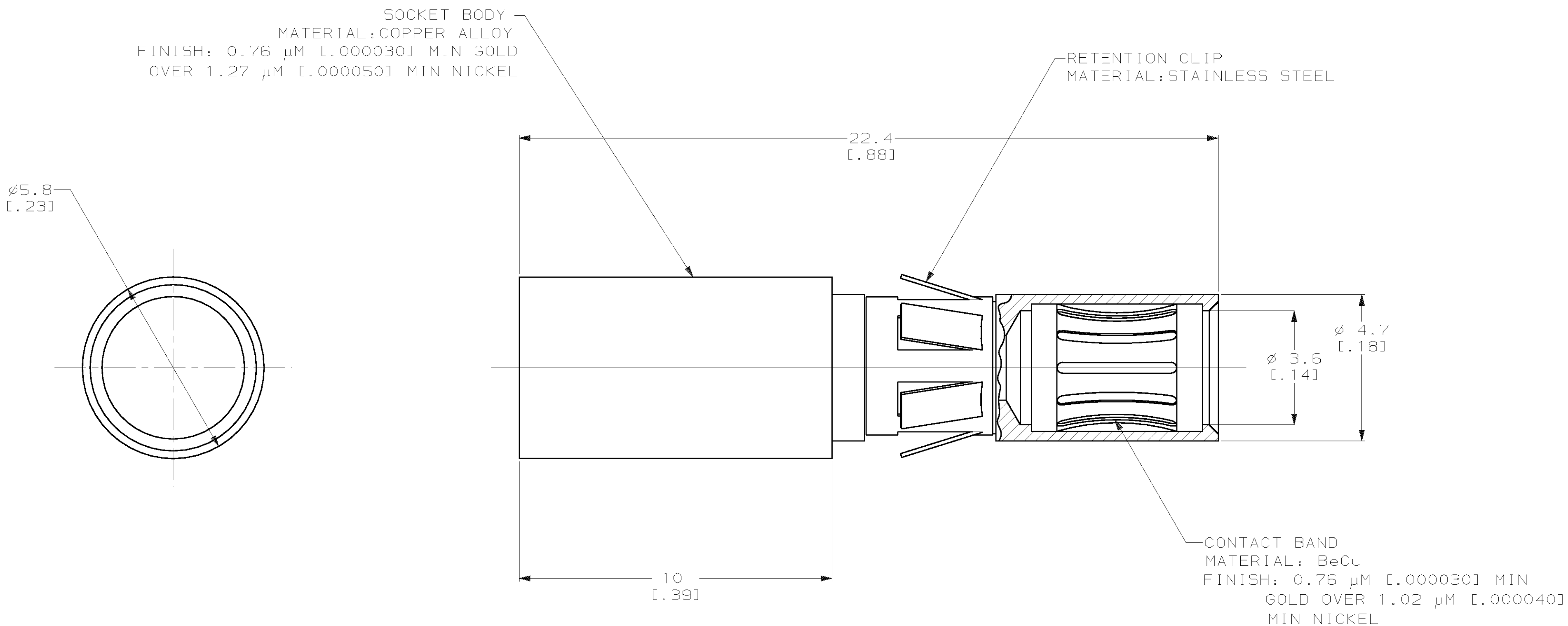

193458-1

PART NO

DO NOT SCALE PRINT. UNLESS SPECIFIED DIMENSIONS IN mm [INCHES] TOLERANCES ON : 2 PLC DEC ± 0.5 [.02] 3 PLC DEC ± 0.25 [.010] ANGLES ± -	DR D. WILSON 05-27-92	AMP Incorporated Harrisburg, PA 17105-3608
	CHK S. SIEGRIST 05-27-92	
	APPD A. GRIFFIN 05-27-92	
	APPD P. GLASER 05-27-92	
MATERIAL	PRODUCT SPEC	NAME  SOCKET, POWER, #8 AWG
FINISH	APPLICATION SPEC	
WEIGHT	SCALE 10:1	SIZE CAGE CODE DRAWING NO C 00779 C=193458
		SHEET 1 OF 1

WAS 92-9991-003

THIS DRAWING IS A CONTROLLED DOCUMENT FOR AMP INCORPORATED. IT IS SUBJECT TO CHANGE AND THE CONTROLLING ENGINEERING ORGANIZATION SHOULD BE CONTACTED FOR THE LATEST REVISION.