

PART NUMBER	REV	FIRST USED
466317-1	A	954400-1
466317-2	C	565435-5

OBSOLETE

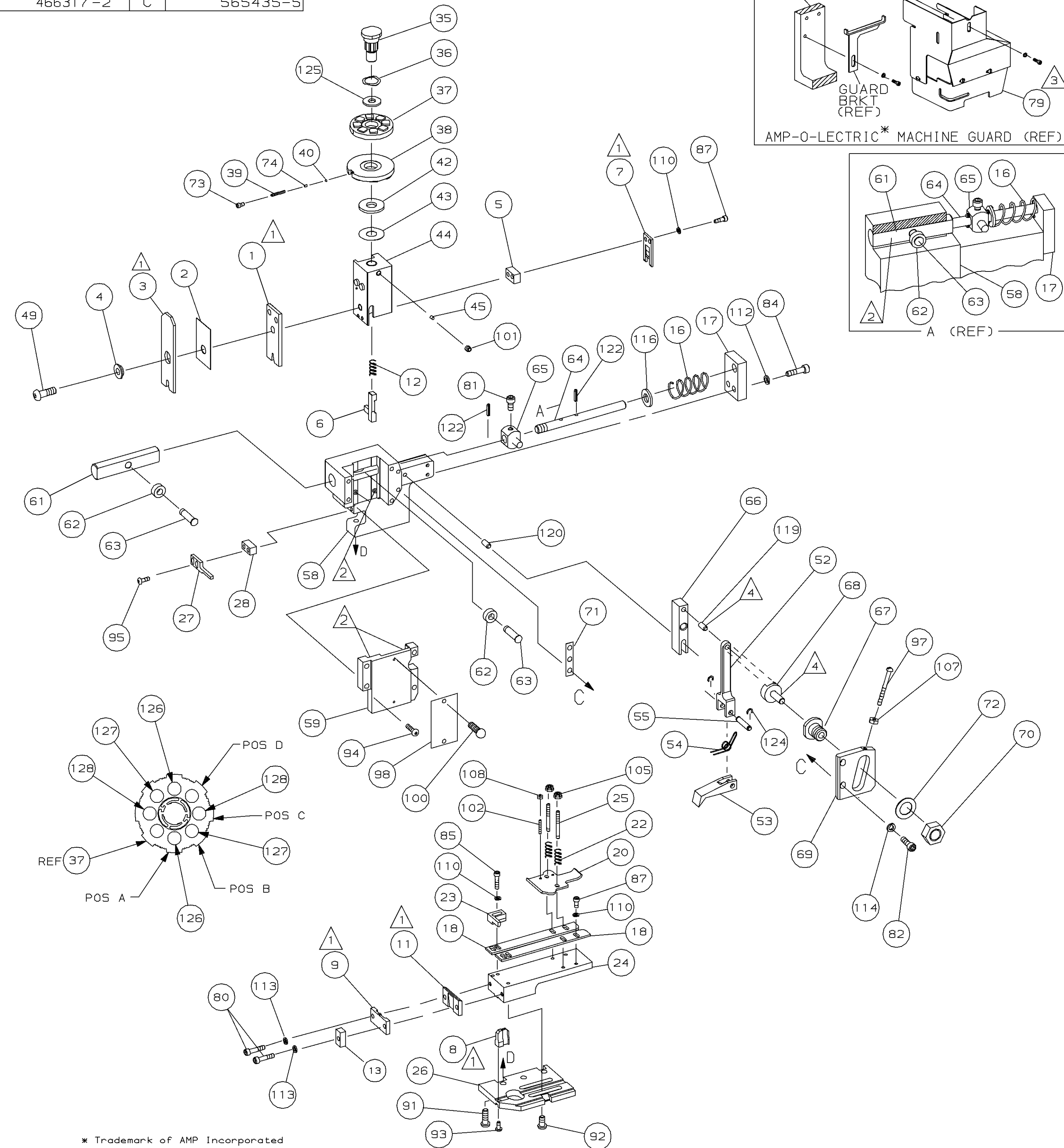

* Trademark of AMP Incorporated

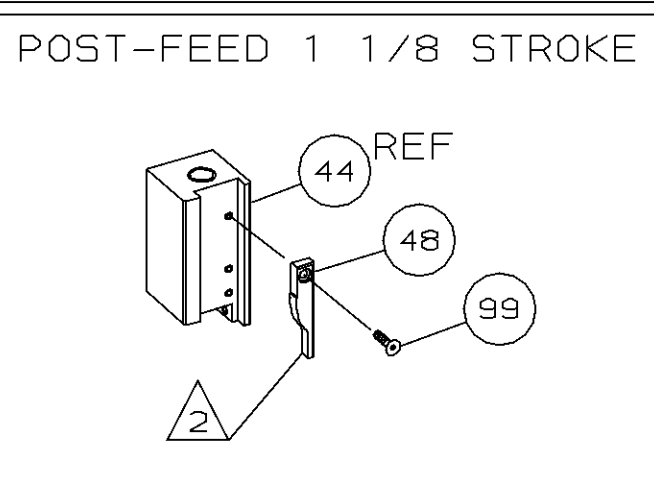
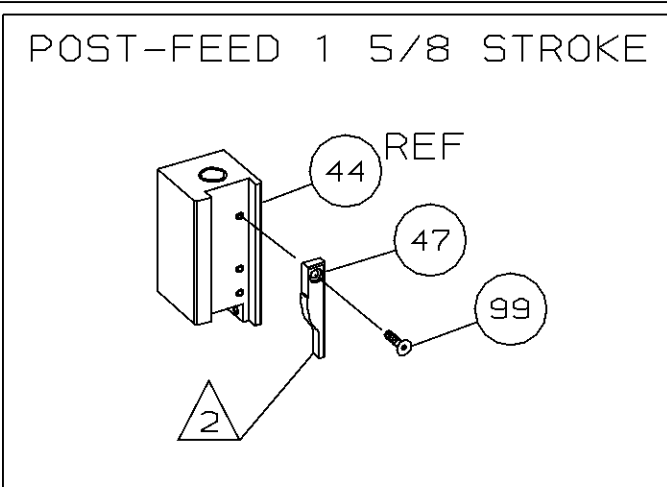

- 1 RECOMMENDED SPARE PARTS.
 - 2 GREASE LIGHTLY.
 - 3 GUARD MUST BE IN PLACE WHEN OPERATING APPLICATOR IN AMP-O-ELECTRIC MACHINE.
 - 4 LUBRICATE DAILY USING NO. 20 MACHINE OIL.
5. ITEMS WITH QTY OF REF SPECIFIED (EXCEPT ITEM 79) ARE USED ON ITEM 32.

TERMINAL NAME:	
.250 FASTON RECEPTACLE	735213

CRIMPING DATA			
PAD LTR	CRIMP HEIGHT	WIRE SIZE	
A	.062 ±.002	14	
B	.060 ±.002	16	
C	.058 ±.002	18	
D	NOT USED	USED	
CRIMP	SIZE	TYPE	RANGE
WIRE	.110	F	18-14
INSUL	.180	F	.120-.170
FEED	APPL INST	SET UP GAGE	LAYOUT
.740	408-8039	458638-1	615
WIRE STRIP LENGTH			
-			

-1	LEADMAKER	MECH-POST FEED	
-2	AMP-O-ELECTRIC	MECH-POST FEED	
REF	REF	- A	22594-8 NUT, HEX 70
REF	REF	- B	240628-1 PLATE, ADJ 69
REF	REF	- B	240626-1 SHAFT, PIVOT 68
REF	REF	- B	240633-1 BUSHING 67
REF	REF	- A	455680-1 LEVER, INTERMEDIATE 66
REF	REF	- B	240629-1 BLOCK, PIVOT 65
REF	REF	- A	240632-2 SCR, ADJ 64
REF	REF	- B	240659-3 PIN, CAM ROLLER 63
REF	REF	- B	240658-1 CAM, ROLLER 62
REF	REF	- B	454398-1 ROD, FEED 61
			60
REF	REF	- C	454220-1 CAP, RAM 59
REF	REF	- D	453736-1 HOUSING 58
			57
			56
REF	REF	- B	240624-1 PIN, FEED FINGER 55
REF	REF	- B	691499-1 SPRING, FEED FINGER 54
REF	REF	- B	240635-1 FINGER, FEED 53
REF	REF	- B	240634-1 LEVER, TERMINAL 52
			51
			50
1		- A	7-21002-9 BOLT, CRIMPER (5/16-24x1.00) 49
1		- B	690501-3 CAM, POST FEED 1 1/8 ST 48
-		- B	690501-4 CAM, POST-FEED 1 5/8 ST 47
			46
1		- A	690191-1 PLUG, NYLON 45
1		- C	455674-1 RAM 44
1		- A	690125-1 WASHER, LAMINATED 43
1		- A	690124-1 WASHER, RAM 42
			41
1		- A	23241-6 BALL, STEEL 40
1		- A	690170-1 SPRING, COMPRESSION 39
1		- C	690142-1 DISC, INSULATION 38
1		- D	354777-1 WIRE DISC, PLASTIC 37
1		- A	22480-5 WASHER, SPRING 36
1		- B	690212-1 POST, RAM 35
			34
			33
1		- D	458980-1 APPLICATOR, BASIC (SUB ASSY) 32
			31
			30
			29
1		- B	3-690451-2 SPACER, STRIPPER 28
1		- A	240639-1 STRIPPER 27
REF	REF	- C	455676-1 PLATE, BASE 26
2	2	- A	22354-8 DRAG, STUD 25
1		- B	458803-2 PLATE, STRIP GUIDE 24
1		- C	240825-2 PLATE, STRIP HOLD DOWN 23
2	2	- A	4-22281-1 SPRING, DRAG 22
			21
1		- A	454177-1 DRAG, STOCK 20
			19
2	2	- C	454204-3 GUIDE, STRIP (FRONT) 18
REF	REF	- A	454178-1 GUIDE, FEED ROD 17
REF	REF	- A	4-22284-9 SPRING, FEED RETURN 16
			15
			14
1		- C	690481-7 SPACER, HOLD DOWN 13
1		- A	23846-1 SPRING, HOLD DOWN 12
1		- B	240833-2 PLATE, REAR SHEAR 11
			10
1		- B	690482-5 PLATE, FRONT SHEAR 9
1		- D	2-240693-3 ANVIL 8
1		- B	690474-5 BLADE, SLUG 7
1		- D	1-455892-1 HOLD DOWN, TERMINAL 6
1		- C	240641-6 SPACER, SLUG BLADE 5
1		- B	238009-1 SPACER, BLOCK CRIMPER 4
1		- C	4-456134-6 CRIMPER, INSULATION 3
1		- B	455888-3 SPACER, CRIMPER 2
1		- C	456408-7 CRIMPER, WIRE 1

QTY	REV	U/M	DWG SIZE	PART NO	DESCRIPTION	ITEM NO
2	2	- C		354779-6	PIN, WIRE DISC (.3020)C	129
2	2	- C		354779-2	PIN, WIRE DISC (.3000)B	127
2	2	- C		354779-8	PIN, WIRE DISC (.3030)A	126
1	1	- A		986950-1	WASHER, FLAT PRECISION	125
REF	REF	- A		21045-3	RING, RET "C" (Ø.187)FD PIN	124
						123
REF	REF	- A		5-21028-1	PIN, STD SPRING (Ø.12)FD ADJ ROD	122
						121
REF	REF	- A		1-21030-7	PIN, DOWEL (Ø.187x1.50)HSG	120
REF	REF	- A		1-21030-1	PIN, DOWEL (Ø.187x.50)LEVER	119
						118
						117
REF	REF	- A		21899-4	WASHER, FLAT (Ø5/16) SCR ADJ	116
						115
REF	REF	- A		21024-5	WASHER, LOCK (NO.10)FD ADJ PL	114
2	2	- A		21024-5	WASHER, LOCK (NO.10) SHEAR PL	113
REF	REF	- A		21024-5	WASHER, LOCK (NO.10)FD ROD GDE	112
						111
7	7	- A		21024-4	WASHER, LOCK (NO.8) SHEAR BL	110
						109
2	2	- A		21018-4	NUT, HEX (4-40) DRAG	108
REF	REF	- A		21018-5	NUT, HEX (6-32)FD ADJ PL	107
						106
2	2	- A		21022-2	NUT, HEX SL (8-32)DRAG STUD	105
						104
						103
2	2	- A		4-21078-8	SKT SKT SET (4-40x.75)DRAG	102
1	1	- A		21009-2	SCR, SKT SET (1/4-20x.25)RAM	101
2	2	- A		21017-2	SCR, DRIVE (#2x.19) ID PLATE	100
1	1	- A		1-21002-7	SCR, BHC (6-32x.38) CAM	99
1	1	- B		461264-1	PLATE, IDENTIFICATION	98
REF	REF	- A		6-23715-5	SCR, PAN HD (6-32x1.50)FEED ADJ	97
						96
2	2	- A		2-21002-2	SCR, BHC (8-32x.50) STRIPPER	95
REF	REF	- A		2-21002-9	SCR, BHC (10-32x.75)HSG CAP	94
1	1	- A		22733-8	SCR, BHC (8-32x.38 LW) ANVIL	93
4	4	- A		3-21002-3	SCR, BHC (1/4-20x.50)ST GD PL	92
REF	REF	- A		2-22733-8	SCR, BHC (1/4-20x.62)BASE PL	91
						90
						89
						88
5	5	- A		2-21000-6	SCR, SHC (8-32x.38) SLUG BLADE	87
						86
2	2	- A		2-21000-9	SCR, SHC (8-32x.75)R STP GUIDE	85
REF	REF	- A		3-21000-7	SCR, SKT CAP (10-32x.75)FD GDE	84
						83
REF	REF	- A		3-21000-6	SCR, SKT CAP (10-32x.62)FD ADJ P	82
REF	REF	- A		3-21000-4	SCR, SKT CAP (10-32x.38)PIVOT BL	81
2	2	- A		3-21000-8	SCR, SKT CAP (10-32x.88)SH PL	80
REF	-	- A		455745-1	GUARD, WINDOW	79
						78
						77
						76
						75
1	1	- A		690603-1	SPRING, ASSIST	74
1	1	- A		23030-1	SCR, SKT CAP (6-32x.25)CP DSC	73
REF	REF	- A		458109-1	WASHER, FLAT (SPECIAL)	72
REF	REF	- A		690517-1	SPACER	71

QTY	REV	U/M	DWG SIZE	PART NO	DESCRIPTION	ITEM NO
-2	-1	U/M				

QTY	REV	U/M	DWG SIZE	PART NO	DESCRIPTION	ITEM NO
-2	-1	U/M				

LOC	DIST	NAME
A	66	LEADMAKER
A	66	T TERMINATING UNIT
A	66	AMP-O-ELECTRIC
A	66	KTERMINATING UNIT

THIS DRAWING IS A CONTROLLED DOCUMENT FOR AMP INCORPORATED. IT IS SUBJECT TO CHANGE AND THE CONTROLLING ENGINEERING ORGANIZATION SHOULD BE CONTACTED FOR THE LATEST REVISION.

THIS INFORMATION IS CONFIDENTIAL AND IS DISCLOSED TO YOU ON CONDITION THAT NO FURTHER DISCLOSURE IS MADE BY YOU TO OTHER THAN AMP PERSONNEL WITHOUT WRITTEN AUTHORIZATION FROM AMP INCORPORATED, HARRISBURG, PA.