

LOC		DIST		REV		REVISIONS		DATE	APPD
CM	53	P	F	ZONE	LTR	DESCRIPTION		RV	RS
						N	REV PER EC 0730-0019-94	4-6-94	

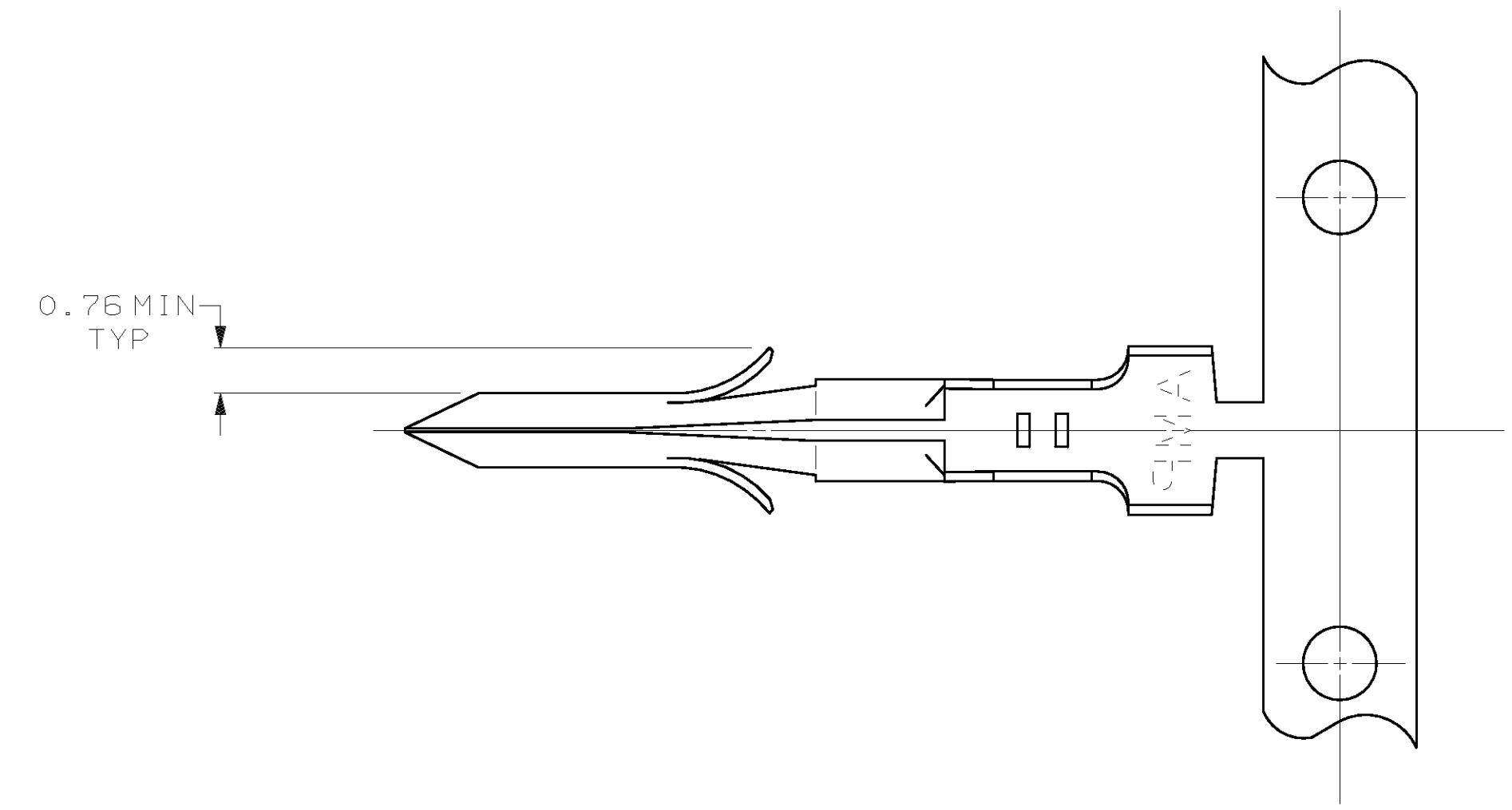

△ NICKEL OVER ENTIRE TERMINAL WITH 0.00076 THICK GOLD OVER 5.08 LENGTH.

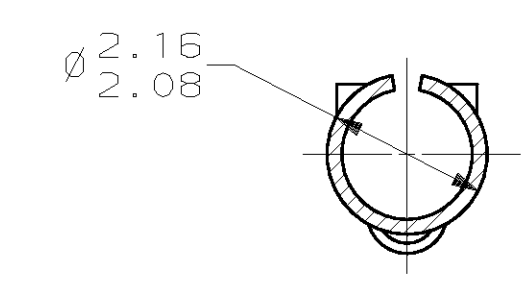
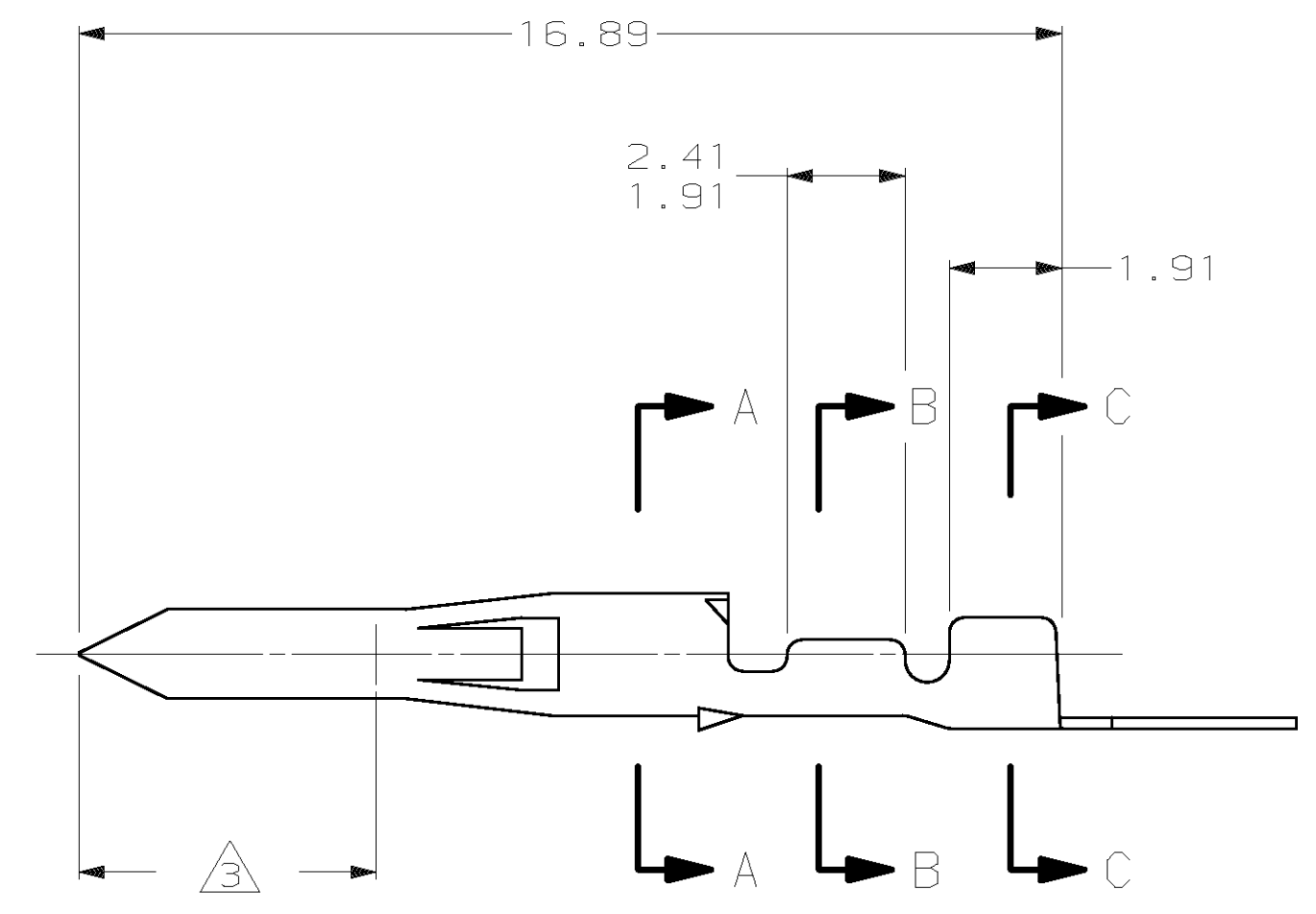
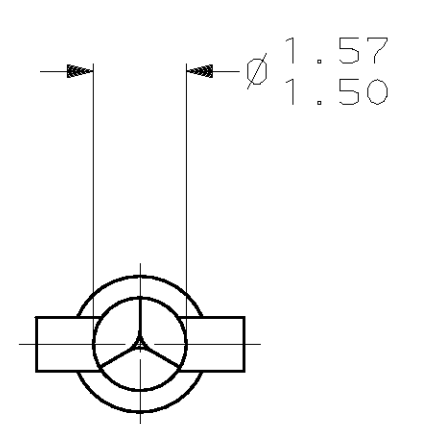

SECTION A-A
SCALE 10:1

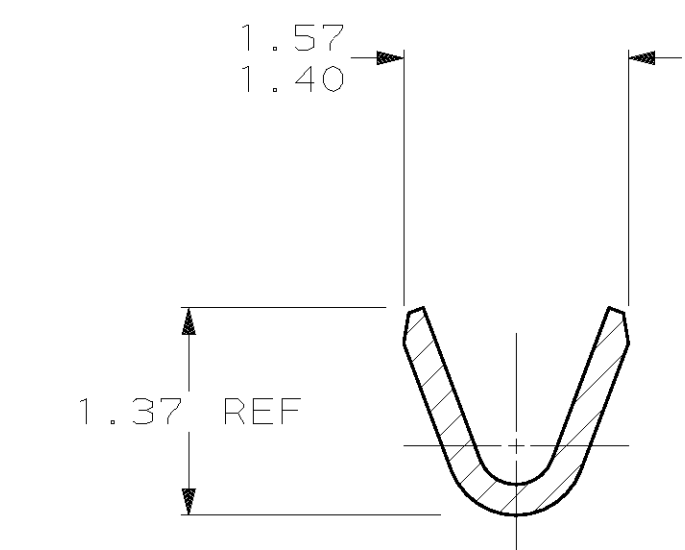

SECTION B-B
SCALE 20:1

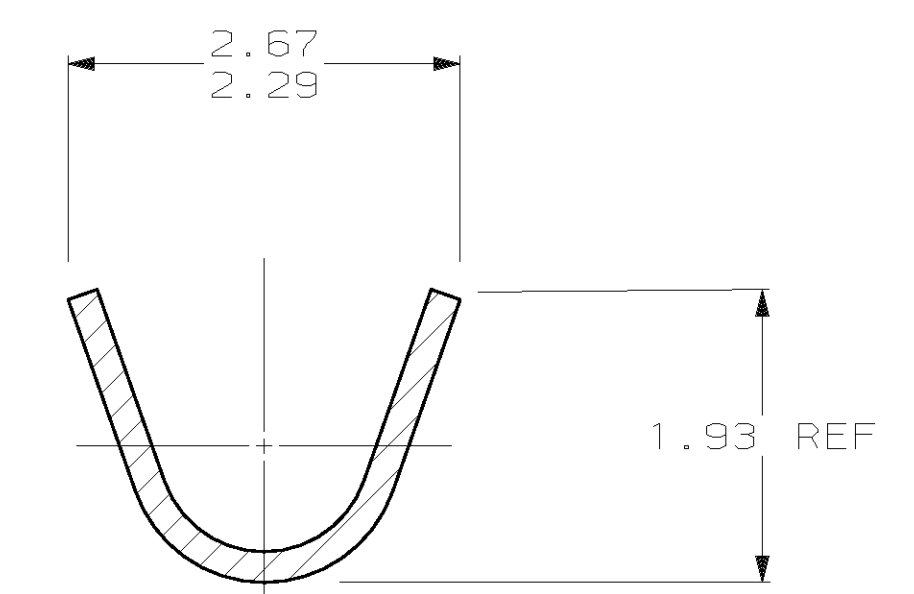

SECTION C-C
SCALE 20:1

1.57	.062	-	-
1.52	.060	16.89	.665
1.50	.059	5.08	.200
1.40	.055	2.67	.105
1.37	.054	2.41	.095
0.76	.030	2.29	.090
0.20	.008	2.16	.085
0.13	.005	2.08	.082
0.00127	.000050	1.93	.076
0.00076	.000030	1.91	.075
MM	IN	MM	IN

CONVERSION TABLE

FINISH	MATERIAL	INSULATION DIAMETER	WIRE RANGE	PART NO
△	0.20 BRASS	1.52 MAX	0.5 - 0.2 mm ² (30-24 AWG)	640391-5
PRE-TIN	0.20 BRASS	1.52 MAX	0.5 - 0.2 mm ² (30-24 AWG)	640391-1

DO NOT SCALE PRINT.
UNLESS SPECIFIED
DIMENSIONS IN mm
TOLERANCES ON:
2 PLC DEC ± -
3 PLC DEC ± 0.13
ANGLES ± -

MATERIAL
SEE TABLE

FINISH
SEE TABLE

DR 9-12-90
B. LEWIS
CHK 9-13-90
R. SWING
APPD 9-27-90
C. CASH
APPD 9-27-90
C. CASH
PRODUCT SPEC
-
APPLICATION SPEC
-
WEIGHT -

AMP AMP Incorporated
Harrisburg, PA 17105-3608

NAME
.062 PIN,
COMMERCIAL PIN AND SOCKET

SIZE D
CAGE CODE 00779
DRAWING NO 640391
SCALE 8:1
SHEET 1 OF 1

