

LOC	DIST	REVISIONS			
P	LTR	DESCRIPTION	DATE	DWN	APVD
FT	8				
	N	REDRAWN W/O CHANGE PER EC 0320-98-96	24 NOV 97	-	-
	N1	REVISED PER ECO-09-021826	11JAN10	KK	AEG

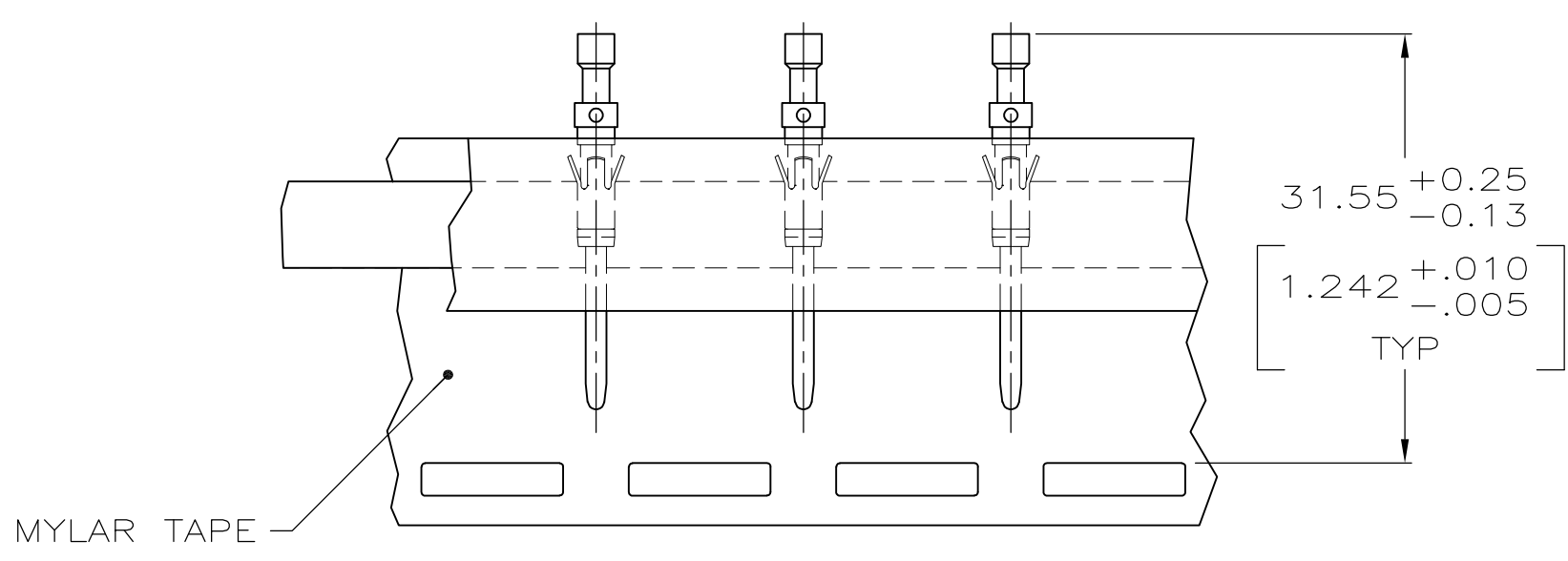
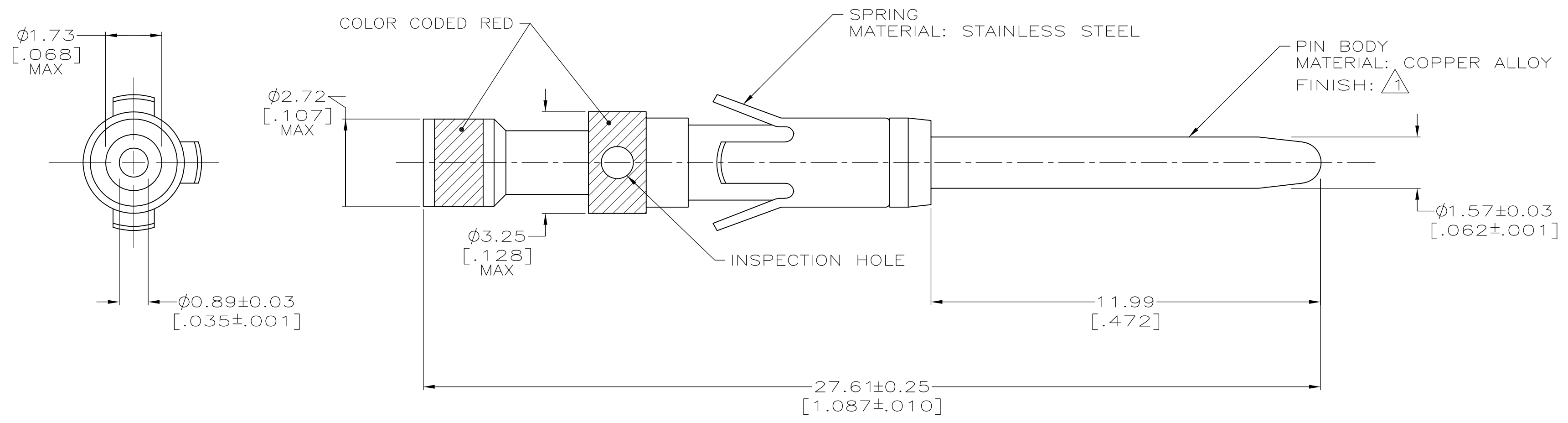

TAPE MTG DETAIL
SCALE 2:1

- Δ 0.76 μm [.000030] MIN GOLD OVER 1.27 μm [.000050] MIN NICKEL.
- Δ WHEN ORDERING CONTACT ASSEMBLY ON TAPE, ORDER BY THE TAPE NUMBER PLUS THE PACKAGING CODE AS FOLLOWS:
 1. FOR USE WITH AMP TAPETRONIC, PNEUMATIC TOOL-
 - A. 1000 PARTS TO A BOX ADD PACKAGING CODE: 1MBOX
 2. FOR USE WITH 4/8 INDENT STRIPPER CRIMPER-
 - A. 1000 PARTS TO A REEL ADD PACKAGING CODE: 1MREEL
 - B. 5000 PARTS TO A REEL ADD PACKAGING CODE: 5MREEL
- Δ OBSOLETE PARTS: OBSOLETE CIS STREAMLINING PER D.RENAUD/D.SINISI

Δ OBSOLETE	TAPE MTD Δ	201611-4
	STANDARD	201611-1
	PACKAGING TYPE	PART NUMBER

THIS DRAWING IS A CONTROLLED DOCUMENT.		DWN	B. CARBO	24 NOV 97	AMP	AMP Incorporated	
DIMENSIONS: mm [INCHES]		CHK	R. STONE	09 DEC 97		Harrisburg, PA 17105-3608	
TOLERANCES UNLESS OTHERWISE SPECIFIED:		APVD	G. STEINHAUER	16 DEC 97	CONTACT ASSEMBLY, PIN, #16, 24-28AWG, TYPE II		
0 PLC ±-	1 PLC ±-	PRODUCT SPEC		SIZE CAGE CODE DRAWING NO RESTRICTED TO			
2 PLC ±0.13 [.005]	3 PLC ±-	APPLICATION SPEC		A2 00779 201611			
4 PLC ±-	ANGLES ±-	MATERIAL		WEIGHT		SCALE 10:1 SHEET 1 OF 1 REV N1	
SEE CALLOUTS		FINISH		SEE CALLOUTS		CUSTOMER DRAWING	

201611