

Process Interface Motherboard for 16 PI/Ex... Modules

PI/Ex-MB/16/D-SUB

1. Short Description

For signal level matching in large or medium-sized process control systems, in particular for applications in which system cabling is used, multiple channel motherboards are available to accept the pluggable PI/Ex-i-Interface modules.

16 electronic bases are grouped together on a motherboard on a sturdy, rail mountable PC board base, to accept the pluggable electronic modules. The power supply is fed in centrally. On the system side, a multiple plug allows all modules to be connected directly to the input/output module.

- The extremely compact design of these modules allows a high packing density without loss of individual measurement circuit integrity.
- Typical for PI, the self-coding module electronics need merely be snapped into the electronic base where they lock in to be vibration-proof.
- There is no need to remove conductors to replace modules. This simplifies installation and maintenance reducing time, costs and frequency of faults.
- It is simple to retain reserves, as only as many Process Interface modules as are required at the time of initial operation are installed. Costs for otherwise unused channels are therefore not incurred.
- Just as is the case for the module electronics, each base can be labelled easily and conveniently with the marking material from the Phoenix marking range (see Modular Terminal Block catalog).
- The development of individual modules to perfectly suit your applications is unrestricted, e.g with different multiple connectors such as ELCO, D-SUB or FLK to connect to the Phoenix PLC system cabling.

Further Features:

- Redundant supply decoupled from diode
- Fuse monitoring with LED and relay contact (PDT)
- Terminal points for error messages if the fuse burns
- Protection against polarity reversal

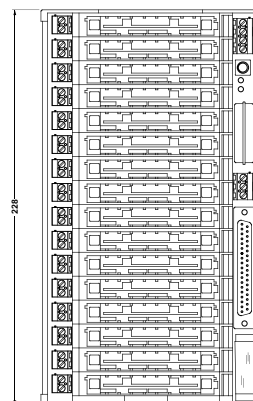
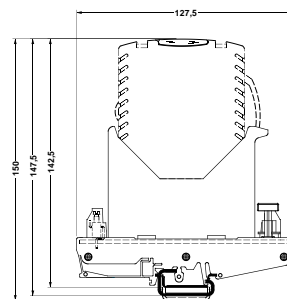
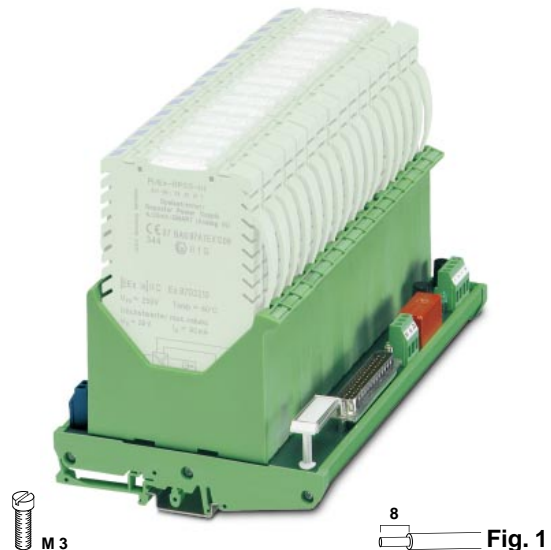

Fig. 2

Circuit diagram
PI/Ex-MB/16/D-SUB

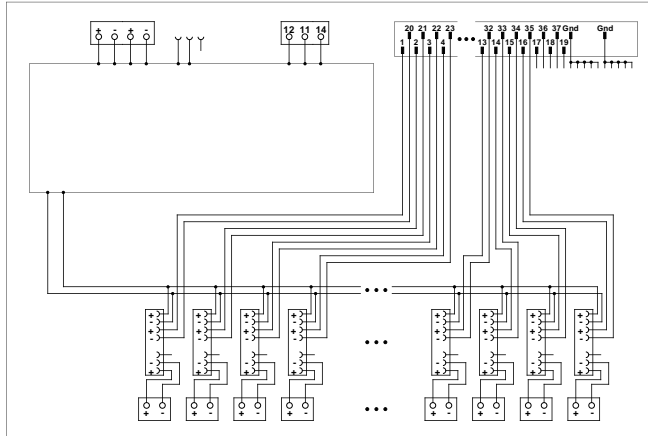

Fig. 3





Fig. 4

2. Technical Data

PI/Ex-MB/16/D-SUB

for 16 PI/Ex... modules

2.1. Description

Motherboard, takeup for 16 PI/Ex... Process Interface modules, for mounting on  or 

2.2. Accessories

System-specific adapter printed circuit boards

Zack marker sheets and marking

2.3. General Data

Connection to control system level

Supply
Nominal voltage
Polarity reversal protection
Operating voltage monitoring

Safety monitoring

Load carrying capacity of alarm contact switching power
switching current
switching voltage

Connection to field level (Ex-area)
Dimensions (W x H x D, equipped)
Approval

2.4. Standards/regulations

Air and creepage distances

(IEC) [mm ²]	rigid solid	flexible stranded	AWG	I [A]	U [V DC]
Connection data	0.2-4	0.2-2.5	24-12	1	35

Type	Order No.	Pcs. Pkt.
PI/Ex-MB/16/D-SUB	28 35 38 3	1

on request

see catalog **Modular Terminal Blocks**

37-pos. D-SUB pin strip (DIN 41652/IEC 807-2)
max perm. current = 1A (125 V AC/DC)
redundant, decoupled from diode
20 -35 V DC
yes
failure of one of the two power supplies is signaled by the green LED extinguishing and the relay contact opening/closing.

a burning fuse is signaled by a red LED and the relay contact opening/closing.
max. 1250 VA
max. 5 A
max. 250 V

16 printed circuit screw terminal blocks (2-pos.)
223 mm x 154 mm x 127.5 mm
acc. to ATEX 100a (EN 50014/EN50020) - applied for

EN 50020
IEC 60664 (1980)/IEC 60664 (1981)
DIN VDE 0110