

Solder Instruction ^(b)

1. Cable should be prepared for soldering.
The cable/wires must be pretinned.
2. Insert cable/wire into solder cup.
3. Operate the soldering iron at 350 °C,
50 Watt max. and use a pencil tip.
4. Put tip to wire in solder cup.
5. After 1 second bring in solder.
6. Heat for 3 seconds longer.
Do not heat contact more than 4 seconds in total.
7. Remove soldering iron.
8. Wait until solder gets rigid again.
9. Do not solder adjacent contacts consecutively,
alternate position within the connector to minimize heat build up.

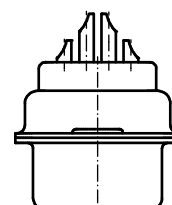
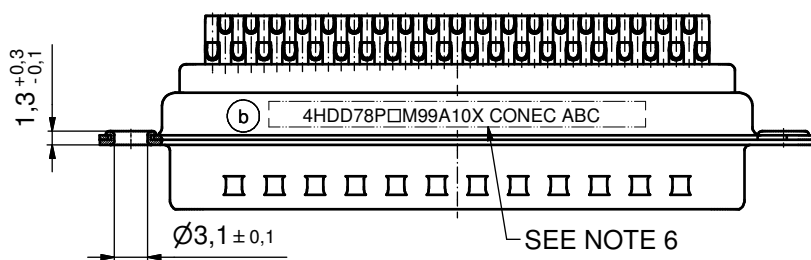
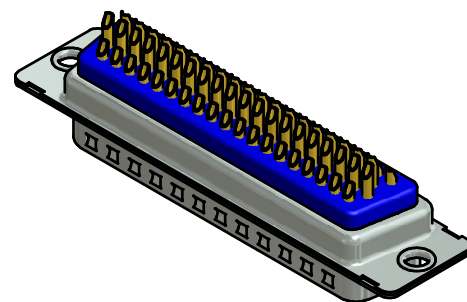
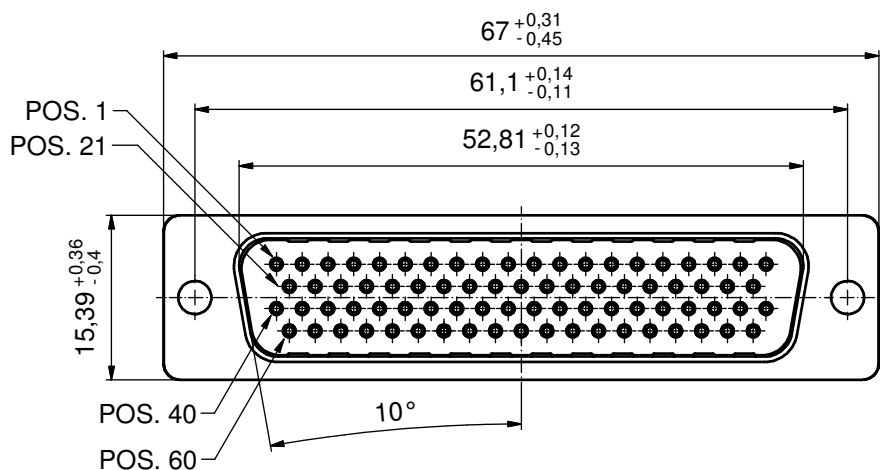
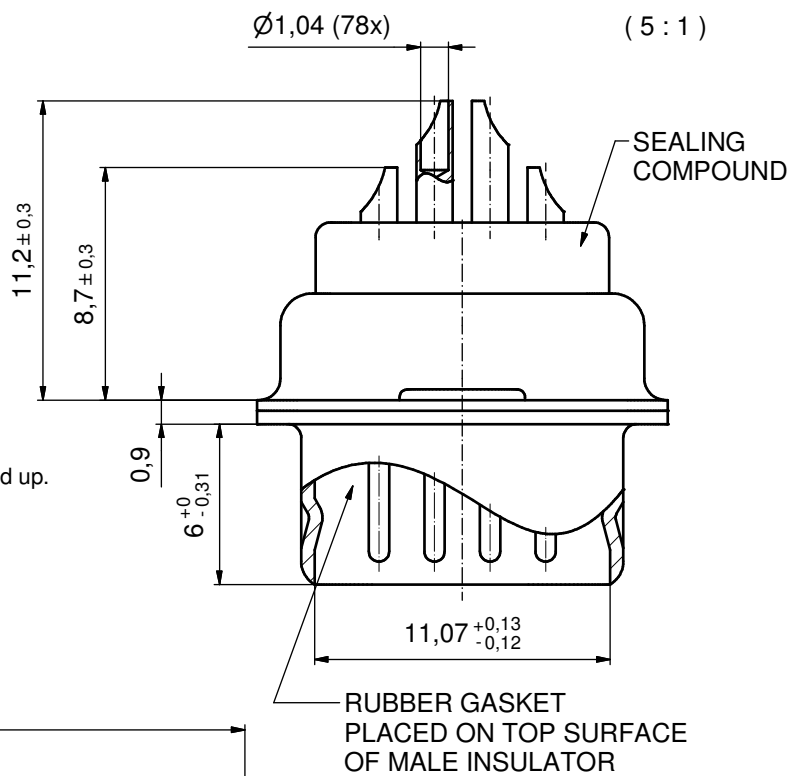

^(b) NOTES:

1. METAL SHELLS: COPPER ALLOY; min. 315µm TIN over 40-80µm NICKEL
2. INSULATORS: PBT GF UL 94 V-0; BLACK
3. SIGNAL CONTACTS: COPPER ALLOY; PLATING (SEE PART NO.):
 PLEASE ADD for GOLD FLASH over NICKEL (PREFERRED TYPE)
 PLEASE ADD for 20µm HARD GOLD over min. 50µm NICKEL
 PLEASE ADD for 30µm HARD GOLD over min. 50µm NICKEL
 PLEASE ADD for 50µm HARD GOLD over min. 50µm NICKEL
 SOLDER CUP ACCEPTS CABLE AWG 22
4. SEALING COMPOUND: PUR; BLUE
5. RUBBER GASKET: TPE; BLACK
6. CONNECTOR IS PART MARKED: 4HDD78P□M99A10X CONEC ABC (see note 3)

RoHS compliant

THIS DRAWING MAY NOT BE COPIED OR REPRODUCED IN ANY WAY, AND MAY NOT BE PASSED ON TO A THIRD PARTY WITHOUT WRITTEN PERMISSION. OWNERSHIP AND COPYRIGHT OF CONEC GmbH DO NOT ALTER CAD DRAWING BY HAND				tolerance		scale: 2:1 (5:1)
				date	name	material: SEE NOTES
				drawn	29.01.15	Henneboel
				appd.	29.01.15	Lehmenkühler
				norm		
				d-old	18K1A264	
4 x b	A5509	29.01.2015	K.H.	title: D-SUB HD MALE 78pos. SOLDER CUP for installation into water resistant hood		
a	Original					
rev.	description	date	name			dwg no: 15K1A1614 ^(b) DIN-A3 sh: 1
						part no: 4HDD78P□M99A10X (see note 6)