

**Impact™
Backplane Module
Installation
Press-In Tool**

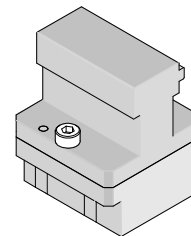

**Application Tooling
Specification Sheet**



Order No. 62201-8824

FEATURES

- Polarized tool prevents product damage
- Tool provides uniform distribution of press force across entire pin array
- May be used as a stand-alone tool or mounted in an optional holder with other Molex press-in tools

SCOPE

Products: Impact™ 85 Ohm Backplane Assembly, 170475 Series, (5-Pair by 16 Column 85 Ohm Assemblies)
See Product List below for specific part numbers.

Product List

The following is a partial list of the product order numbers and their specifications this tool is designed to run.
Updates to this list are available on www.molex.com.

170475 Series Numbers							
Guide Style	Columns	Assembly Order Number					
Open Wall	16	170475-1603	170475-1604	170475-1605	170475-1606	170475-1607	170475-1608
Dual End	16	170475-1623	170475-1624	170475-1625	170475-1626	170475-1627	170475-1628
Left End	16	170475-1613	170475-1614	170475-1615	170475-1616	170475-1617	170475-1618
Right End	16	170475-1633	170475-1634	170475-1635	170475-1636	170475-1637	170475-1638
Left Guided	16	170475-3603	170475-3604	170475-3605	170475-3606	170475-3607	170475-3608
		170475-3613	170475-3614	170475-3615	170475-3616	170475-3617	170475-3618
		170475-3623	170475-3624	170475-3625	170475-3626	170475-3627	170475-3628
		170475-3633	170475-3634	170475-3635	170475-3636	170475-3637	170475-3638
		170475-3643	170475-3644	170475-3645	170475-3646	170475-3647	170475-3648
		170475-3653	170475-3654	170475-3655	170475-3656	170475-3657	170475-3658
		170475-3663	170475-3664	170475-3665	170475-3666	170475-3667	170475-3668
		170475-3673	170475-3674	170475-3675	170475-3676	170475-3677	170475-3678
		170475-3683	170475-3684	170475-3685	170475-3686	170475-3687	170475-3688
		170475-7603	170475-7604	170475-7605	170475-7606	170475-7607	170475-7608
		170475-7613	170475-7614	170475-7615	170475-7616	170475-7617	170475-7618
		170475-7623	170475-7624	170475-7625	170475-7626	170475-7627	170475-7628
		170475-7633	170475-7634	170475-7635	170475-7636	170475-7637	170475-7638
		170475-7643	170475-7644	170475-7645	170475-7646	170475-7647	170475-7648
		170475-7653	170475-7654	170475-7655	170475-7656	170475-7657	170475-7658
		170475-7663	170475-7664	170475-7665	170475-7666	170475-7667	170475-7668
170475-7673	170475-7674	170475-7675	170475-7676	170475-7677	170475-7678		
170475-7683	170475-7684	170475-7685	170475-7686	170475-7687	170475-7688		
Right Guided	16	170475-5603	170475-5604	170475-5605	170475-5606	170475-5607	170475-5608
		170475-5613	170475-5614	170475-5615	170475-5616	170475-5617	170475-5618
		170475-5623	170475-5624	170475-5625	170475-5626	170475-5627	170475-5628
		170475-5633	170475-5634	170475-5635	170475-5636	170475-5637	170475-5638

		170475 Series Numbers					
Guide Style	Columns	Assembly Order Number					
Right Guided	16	170475-5643	170475-5644	170475-5645	170475-5646	170475-5647	170475-5648
		170475-5653	170475-5654	170475-5655	170475-5656	170475-5657	170475-5658
		170475-5663	170475-5664	170475-5665	170475-5666	170475-5667	170475-5668
		170475-5673	170475-5674	170475-5675	170475-5676	170475-5677	170475-5678
		170475-5683	170475-5684	170475-5685	170475-5686	170475-5687	170475-5688
		170475-9603	170475-9604	170475-9605	170475-9606	170475-9607	170475-9608
		170475-9613	170475-9614	170475-9615	170475-9616	170475-9617	170475-9618
		170475-9623	170475-9624	170475-9625	170475-9626	170475-9627	170475-9628
		170475-9633	170475-9634	170475-9635	170475-9636	170475-9637	170475-9638
		170475-9643	170475-9644	170475-9645	170475-9646	170475-9647	170475-9648
		170475-9653	170475-9654	170475-9655	170475-9656	170475-9657	170475-9658
		170475-9663	170475-9664	170475-9665	170475-9666	170475-9667	170475-9668
		170475-9673	170475-9674	170475-9675	170475-9676	170475-9677	170475-9678
		170475-9683	170475-9684	170475-9685	170475-9686	170475-9687	170475-9688

Tool Setup

Depending on the number of connectors to be installed and/or the press used, this tool can be used alone or with a group of press-in tools, mounted in a 62201-95XX rail (ordered separately). See Figure 1.

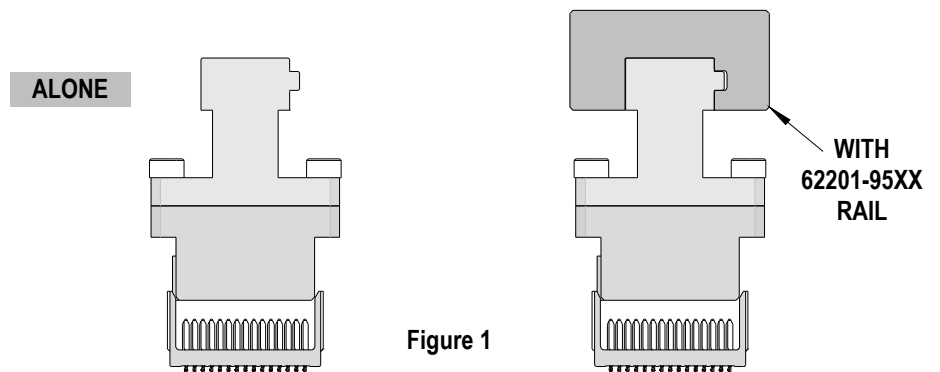

Figure 1

Tool Installation

The 62201-95XX rail is available in a variety of lengths to accommodate multiple press-in tools.

Rail Part Number	Rail Overall Length
62201-9501	24mm (0.94 in)
62201-9502	72mm (2.83 in)
62201-9503	156mm (6.14 in)
62201-9504	216mm (8.50 in)
62201-9509	254mm (10.0 in)
62201-9511	305mm (12.0 in)

Reference: This Press-In Tool is 30.3mm (1.19 in.) long.

Printed Circuit Board (PCB) Support

The Impact™ connectors require up to 3.6kg (8 lb) of force per pin to press into the PCB. To prevent excessive PCB flexure and/or damage to the PCB, a support plate is strongly recommended directly beneath the connector hole pattern.

Due to the custom nature of every application, Molex does not offer any PCB support plate. The customer must furnish their own support plate.

When creating the PCB support plate, remember to allow clearance for the connector pins as they pass through the PCB thickness.

Press Equipment Recommendations

Many types of presses can be used to install Impact™ connectors, but to assure consistent connector installation Molex recommends the following press criteria:

1. The capability to detect force variations as low as 4.5kg (10 lb) during the press-in cycle; excessive force measurements should stop the press-in cycle.
2. The rate of pressing can be regulated as low as 0.13mm (0.005 in) per second.
3. Press stroke control to within 0.25mm (0.010 in).
4. Total press stroke must be at least 19mm (0.75 in).
5. For statistical purposes, automatic collection of force and distance data.

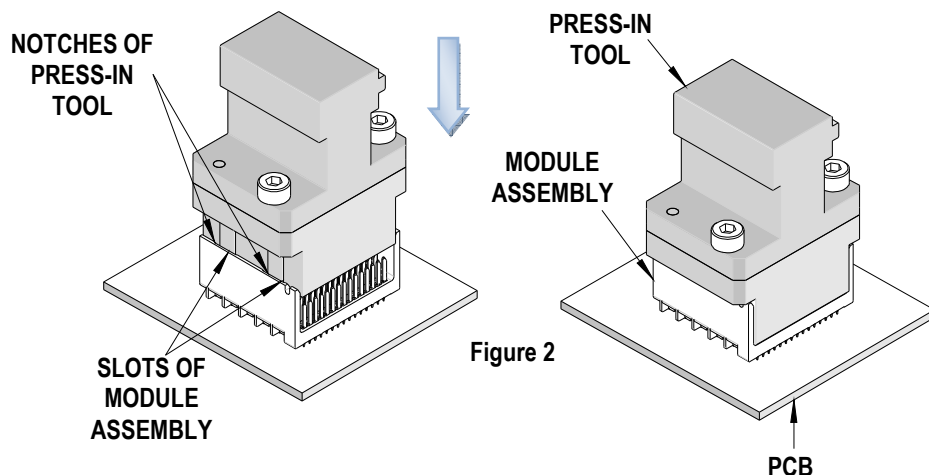

Figure 2

Tool Operation

1. Insert by hand the backplane signal module assembly (s) carefully into the PCB hole pattern. Make sure the connector(s) are oriented properly by confirming the location of the #1 circuit notch with respect to the PCB layout.
2. Insert the Press-In Tool making sure that the notch in this tool is inserted into the slot on top of the connector housing of the backplane signal module assembly. See Figure 2.
3. Using the application tool and an appropriate press, seat the header assembly until there is less than 0.10mm (.004 in) clearance between the bottom of the plastic housing and the surface of the PCB. See Figure 3.

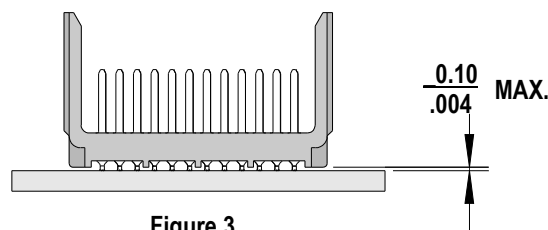

Figure 3

There should be no broken stand-offs along the perimeter of the part (an indication of over-pressing).

CAUTION: To prevent injury, never operate any press without the guards in place. Refer to the press manufacturer's instruction manual.

CAUTION: Molex application tooling specifications are valid only when used with Molex connectors and tooling.

Contact Information

For more information on Molex application tooling please contact Molex at 1-800-786-6539.

<http://www.molex.com>