

THIS DRAWING IS UNPUBLISHED. RELEASED FOR PUBLICATION  
 © COPYRIGHT BY TYCO ELECTRONICS CORPORATION. ALL RIGHTS RESERVED.

| LOC |     | DIST        |             | REVISIONS |         |      |    |
|-----|-----|-------------|-------------|-----------|---------|------|----|
| P   | LTR | DESCRIPTION |             | DATE      | DWN     | APVD |    |
| AF  | 50  | E1          | REV PER ECR | 10-005376 | 11MAR10 | JR   | GP |

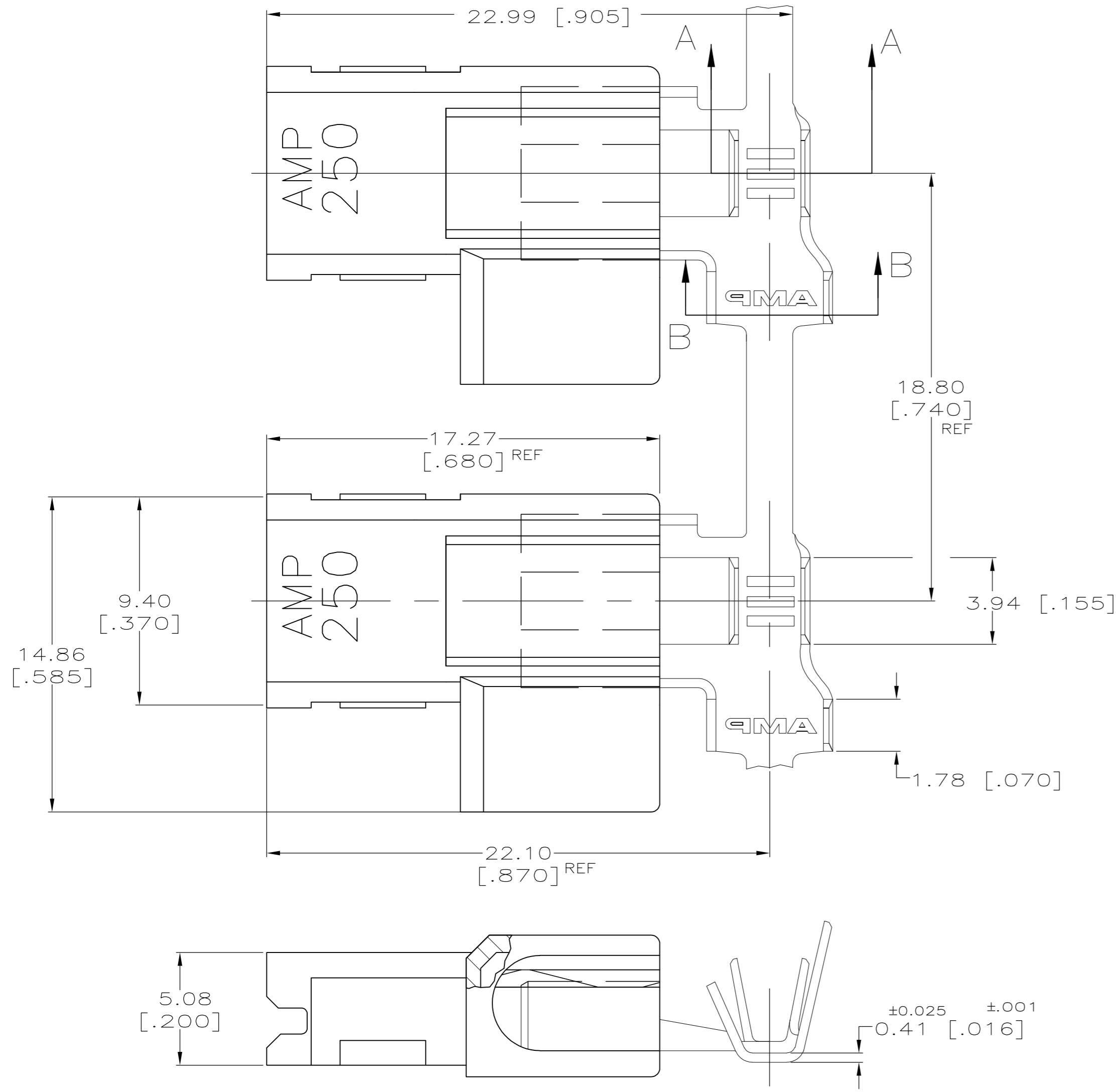

1 BUDGET FLAG FASTON TERMINALS, BASE P/N 521091, ARE USED IN THIS PRODUCT.  
 2 ALTERNATE HOUSING FORM

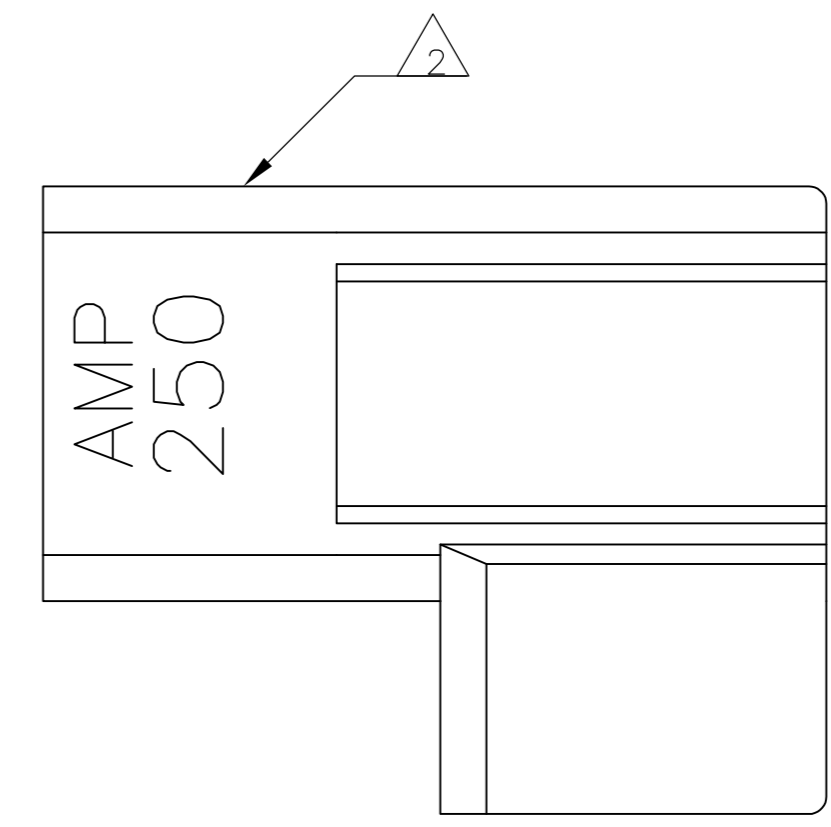
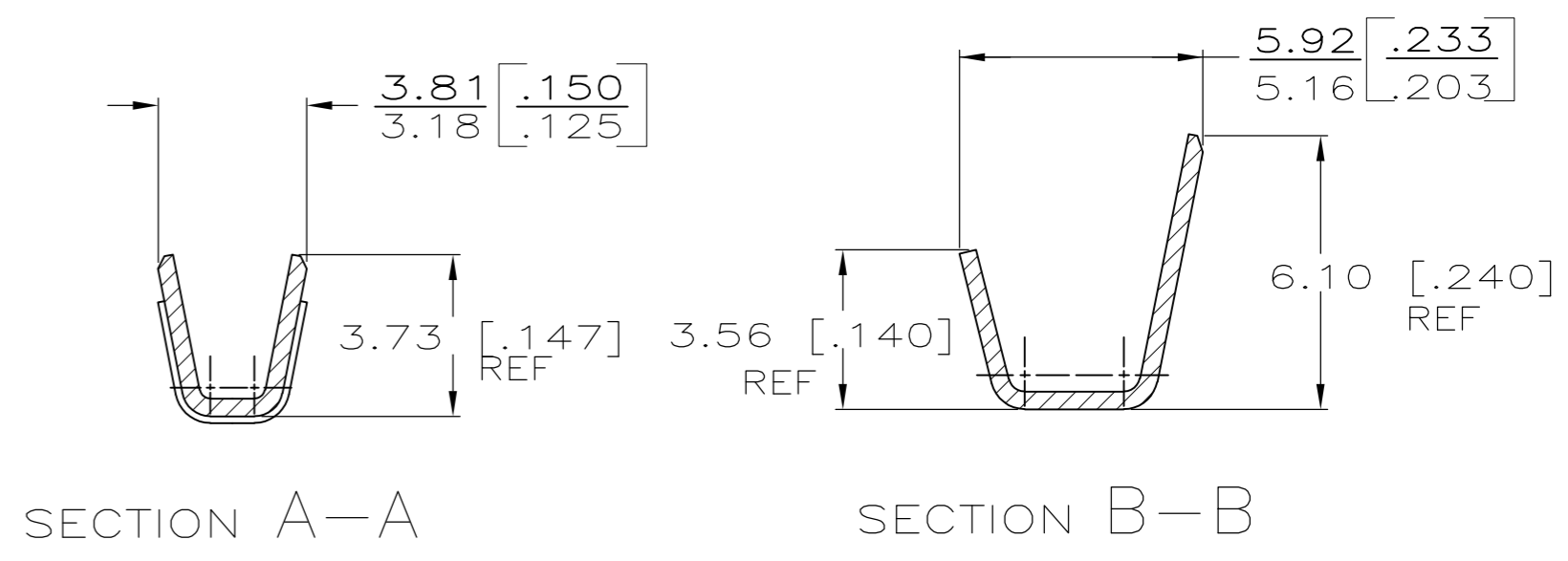

|  |                            |                                  |  |          |
|--|----------------------------|----------------------------------|--|----------|
| 4/6 NYLON / BLACK 150°C                | NICKEL - STEEL             | 2.79-4.06 DIA<br>[.110-.160] DIA | 0.8-2.0mm <sup>2</sup><br>[#18-#14] AWG              | 521087-1 |
| HOUSING MATERIAL / COLOR               | TERMINAL FINISH - MATERIAL | INSULATION RANGE                 | WIRE SIZE  | PART NO  |
| THIS DRAWING IS A CONTROLLED DOCUMENT. |                            | DWN<br>JR RUTH<br>6/27/95        | Tyco Electronics Corporation<br>Harrisburg, PA 17105 |          |
| DIMENSIONS:<br>INCHES                  |                            | CHK<br>MS FEHER<br>6/27/95       | NAME<br>D BRATINA                                    |          |
| TOLERANCES UNLESS OTHERWISE SPECIFIED: |                            | APVD<br>6/27/95                  | PRODUCT SPEC<br>108-1285                             |          |
| 0 PLC ± -                              |                            | APPLICATION SPEC<br>114-2124     |  |          |
| 1 PLC ± -                              |                            | SIZE<br>A2                       |  |          |
| 2 PLC ± -                              |                            | CAGE CODE<br>00779               |  |          |
| 3 PLC ± 0.25 [.010]                    |                            | DRAWING NO<br>C=521087           |  |          |
| 4 PLC ± -                              |                            | RESTRICTED TO<br>-               |  |          |
| ANGLES ± -                             |                            | SCALE<br>6:1                     |  |          |
| FINISH<br>SEE TABLE                    |                            | SHEET<br>1 OF 1                  |  |          |
| MATERIAL<br>SEE TABLE                  |                            | REV<br>E1                        |  |          |
| CUSTOMER DRAWING                       |                            |                                  |  |          |