

| | | | | | | | | | | | | | | | | | | | | | | | | | | | | | | | |
|----------|----|----|----|----|----|----|----|----|----|----|----|----|----|----|----|----|----|----|----|----|----|----|----|----|----|----|----|----|----|----|----|
| GEN. ST. | 01 | 02 | 03 | 04 | 05 | 06 | 07 | 08 | 0D | 50 | 60 | 70 | 80 | 90 | | | | | | | | | | | | | | | | | |
| INT. ST. | 10 | 11 | 12 | 13 | 14 | 18 | 20 | 31 | 32 | 33 | 34 | 38 | 39 | 40 | 42 | 43 | 44 | 45 | 46 | 48 | 56 | 70 | 72 | 73 | 75 | 76 | 81 | 82 | 83 | 84 | 88 |

| REV. | DATE | DESCRIPTION | BY | C'K'D' |
|------|------------|------------------------|--------|--------|
| A | 2001-09-14 | CONVERSION REVISION 01 | KN | |
| B | 2002-05-28 | EC B20086 | MF | |
| C | 2005-11-07 | 105-0221 | ALEX B | BKP |
| D | 2006-08-03 | 106-0119 | ALEX B | BKP |

LOADING PATTERN MATING SIDE

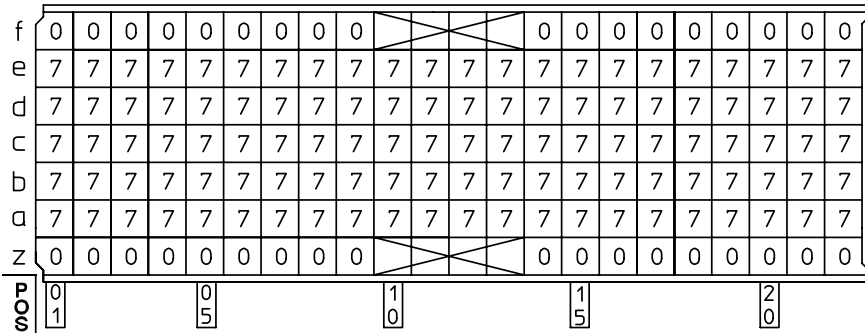

LOADED CONNECTOR ASSEMBLY
(FOR EXAMPLE)

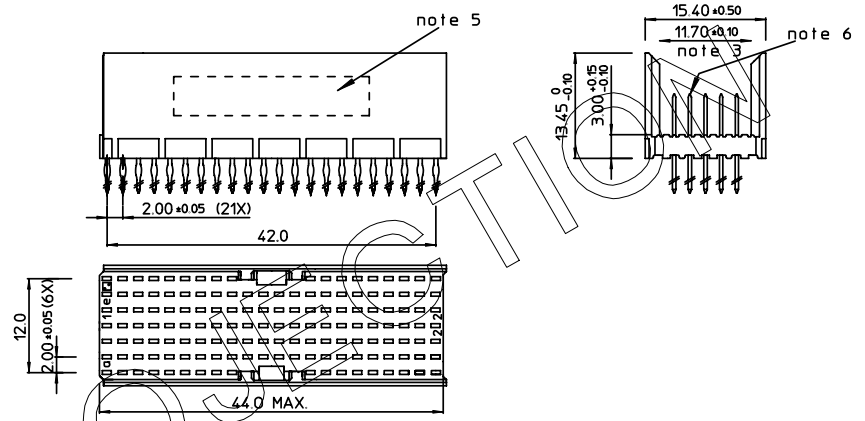

SHEET NR. :

CONTACT OVERVIEW

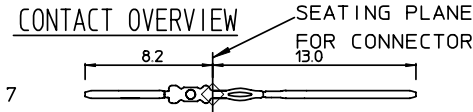

LAY-OUT P.C.B.-HOLE

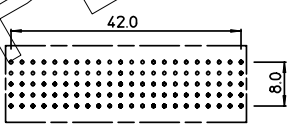

HM2P66PK5110

LEAD FREE INDICATOR : LF = LEAD FREE (DIGIT 15 & 16)

PLATING CODE (DIGIT 13 AND 14) (REF DWG No. BS,C ,201844,003)

NOTES:

1. THIS PRODUCT IS CSA APPROVED.
2. THIS PRODUCT IS UL RECOGNIZED.
3. MEASURED AT THE BOTTOM.
4. MATERIAL CONTACT: PHOSPHORBRONZE
HOUSING: CREAM WHITE GLASSFILLED POLYESTER UL-94V0
5. CONNECTOR PRINTED WITH P/N AND DATE CODE.
6. FOR ACTUAL CONTACT LOADINGS, SEE LOADING PATTERN MATING SIDE.
7. SHAPE OF CONNECTOR HOUSING CAN ALTER DEPENDING ON PRODUCTION LOCATION.
8. THE PRODUCT (LF) MEETS EUROPEAN UNION DIRECTIVES AND OTHER COUNTRY REGULATIONS AS DESCRIBED IN GS-22-008
9. FOR RECOMMENDED PTH DIMENSIONS REFER DRAWING : BS,A ,201572,001

EUROPEAN PRO

| | | | | |
|---|--|--------------------|-----------------|---------------------------------------|
| 1DEC ±0,2 2DEC ±0,1 ANGLES ±1° | APPR. DRAFT CHECKED | DATE 2009-04-27 | SIGN. M.Fret | LOADING PATTERN OVERVIEW |
| WE RESERVE THE RIGHT TO CHANGE DIMENSIONS OR REQUIREMENTS WITHOUT PRIOR NOTICE. | PROD. MGR. PR. ENG. MGR. PR. MGT. MGR. | | | CAT. No. HM2P66PK5110---- |
| ALL DIMENSIONS IN MM | | | | FCJ www.fciconnect.com |
| | | | | SCALE |
| | | | | BS,C ,201843,973 |
| | | | | D |
| | | | | DRAWING No. CUSTOMER DRAWING REVISION |

THIS IS OUR EXCLUSIVE PROPERTY. IT IS NOT TO BE COPIED, REPRINTED OR DISCLOSED TO A THIRD PARTY. NOT USED FOR MANUFACTURING WITHOUT OUR WRITTEN CONSENT, AND HAS TO BE RETURNED TO US IN CASE OF NO USAGE

DIT IS ONZE EIGENDOM EN MAG NIET AFGEMAAKT, HEROPKART, OVERGEMAAKT AAN DEREN, NOCH VOOR FABRICATIE GEBRUIKT WORDEN, ZONDER ONZE SCHRIFTELIJKE TOELATING. BIJ NIET GEBRUIK IS TERUGZENDING VERPLICHT.