

-1: 本図
-1: AS SHOWN

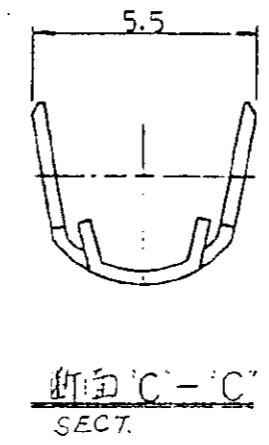
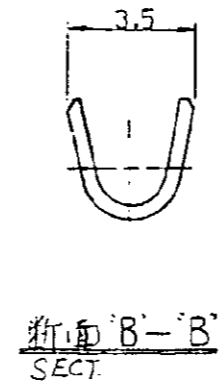
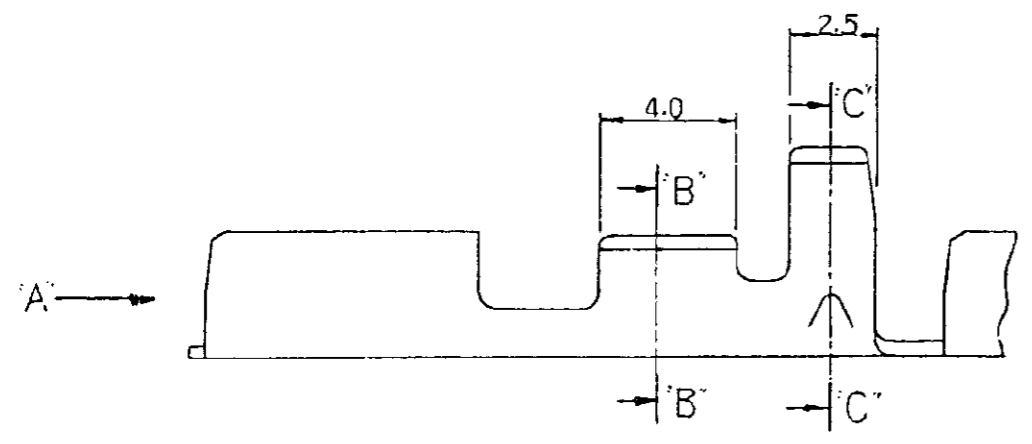
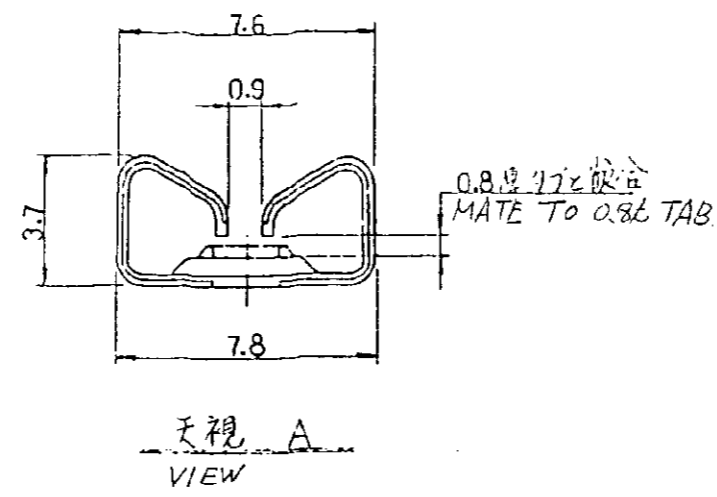
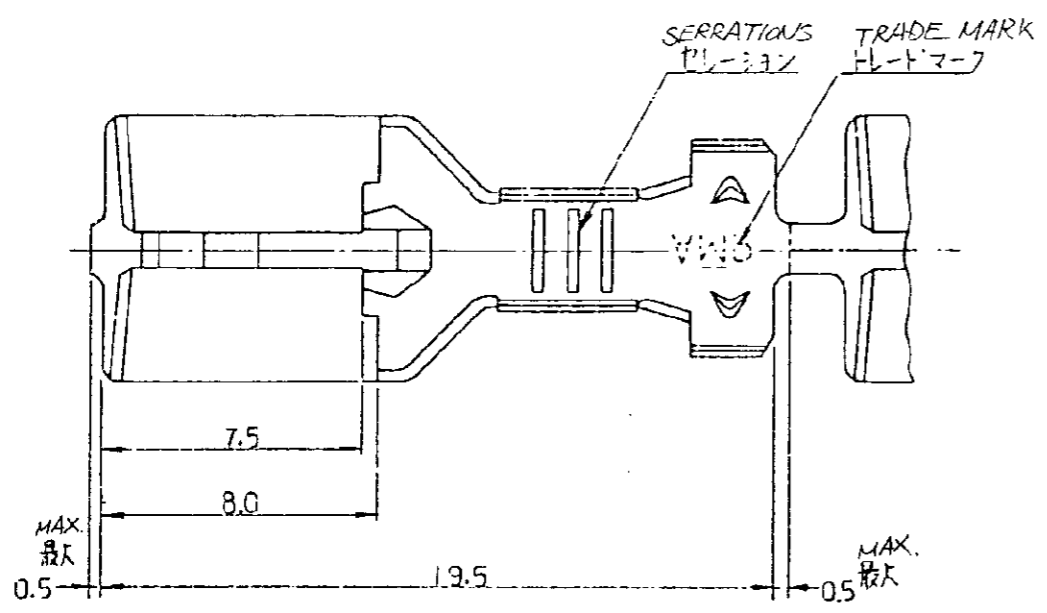

注：
1. ストレス除去処理
処理方により外観が異なります。
不活性ガス加熱方式 - - 無光沢
大気加熱方式 - - 光沢

NOTES:
1. STRESS RELIEVING
FINISH IS SUBJECT TO CHANGE BY THE TYPE OF
STRESS RELIVING PROCESS
INERT GAS FURNACE - - - -MATTE
ATOMOSPHERIC FURNACE FOLLOWED BY ACID PICKLE - - - -BRIGHT

PRINT DIST DIMENSIONS IN MM DO NOT SCALE PRINT

C 日本アイ・エム・ピー株式会社 AMP (Japan) LTD.		C 日本アイ・エム・ピー株式会社 AMP (Japan) LTD.		AMP (Japan) LTD. TOKYO, JAPAN	
WIRE RANGE: 0.85-2 AWG #4		INSULATION DIA: 22-34		PART NAME: .250 SERIES RECEPTACLE CONTACT, "M" TYPE .250 シリーズ リセプタクル コンタクト M型	
MATERIAL: BRASS 黄銅 0.32		FINISH: (FINISH)		REV: B LOC: J (NO): C-171656	
A 変更 FJ00-5023-8175 1/15		O 作 成 J83-7324 2/4 4/1/83		SCALE: 5:1 REV: A SHEET: 1	
LTD. REVISION RECORD		CHK: [Signature]		APP: [Signature]	