



Switching spark gap

SSG with lead wires

Series/Type: FS08X-1GH
Ordering code: B88069X0340xxxx ^{a)}
Version/Date: Issue 08 / 2006-08-30

© EPCOS AG 2015. Reproduction, publication and dissemination of this publication, enclosures hereto and the information contained therein without EPCOS' prior express consent is prohibited.

EPCOS AG is a TDK Group Company.

Features	Applications
<ul style="list-style-type: none"> ▪ Extremely long life time ▪ Stable performance over life ▪ Insensitive performance against variations in temperature ▪ Very low switching losses ▪ Very short breakdown time ▪ High reliability by robust design ▪ RoHS compatibility 	<ul style="list-style-type: none"> ▪ Ignition of HID lamps

Electrical specifications

Nominal breakdown voltage V_N	800	V
Initial values ²⁾		
Static breakdown voltage V_S ¹⁾		
First ignition value $V_{S, FTE}$ after 24 hours in darkness	≤ 950	V
Following ignition values $V_{S, FIV}$	704 ... 896	V
Electrical life time ³⁾		
Breakdown voltage V_B up to 100 000 Ignitions		
First ignition value $V_{B, FTE}$ after 24 hours in darkness	≤ 1000	V
Ignition time t_i at V_0 during life	≤ 60	ms
Following ignition values $V_{B, FIV}$ at 50 000 Ignitions	704 ... 920	V
Following ignition values $V_{B, FIV}$	680 ... 920	V
Switching operations in total	100 000	Ignitions
at - 40; +150 °C, each	10 000	Ignitions
at + 25; +125 °C, each	40 000	Ignitions
Test circuit parameters		
Open circuit voltage V_0	1000	V
Loading resistance R	56	k Ω
Discharge capacitance C	114	nF
Inductance L	0.13	μ H
Discharge peak current I_P	~ 660	A
General technical data		
Insulation resistance at 100 V	> 100	M Ω
Early ignition values between 530 ... 680 V	≤ 1	%
Breakdown time	≤ 50	ns
Maximum loading current	50	mA
Weight	~ 2	g
Marking, blue positive	EPCOS 800 WWY O 800 - Nominal voltage WW - Calendar week of production Y - Year of production O - Non radioactive	

a) xxxx = T502 (taped and reeled with 500 pcs.)
 = T103 (taped and reeled with 1000 pcs.)

1) At delivery AQL 0,65 level II, DIN ISO 2859

2) Page 2, Fig. 1 and 2

3) Page 2, Fig. 3 and 4

Figures

Fig. 1: QC- test circuit (100% outgoing inspection)

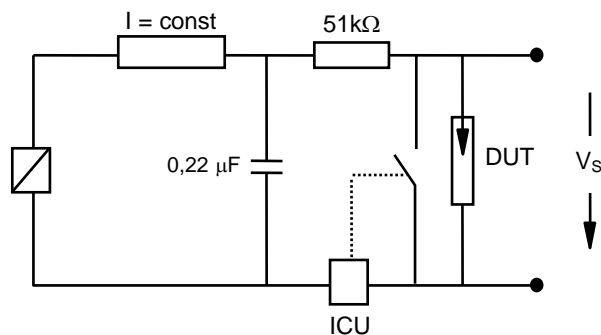

DUT device under test
 ICU ignition control unit (sensitivity 10 ... 30 μA)
 Discharge current 10 – 20 mA

Fig. 2: Explanation of measurands

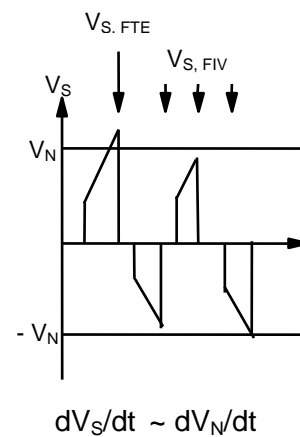

Fig. 3: QC- test circuit (sampling inspection at 25 °C)

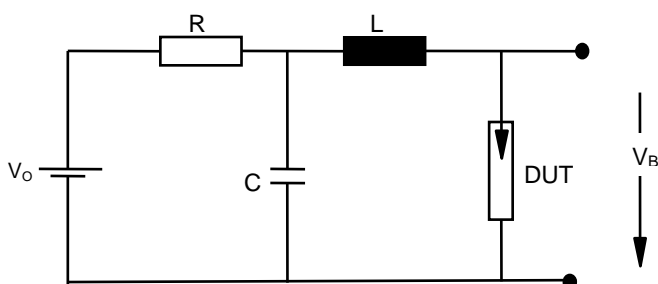
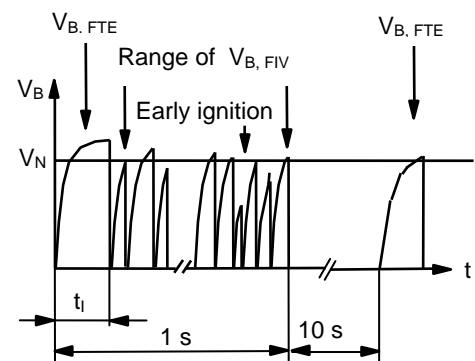
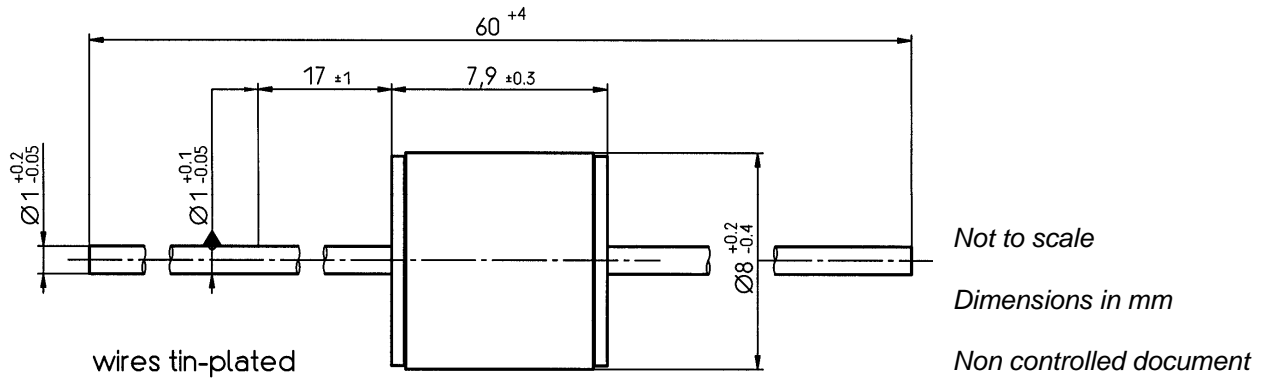

Fig. 4: Explanation of measurands



Dimensional Drawing

Cautions and warnings

- Switching spark gaps may be used only within their specified values.
- Damaged switching spark gaps must not be re-used.

Important notes

The following applies to all products named in this publication:

1. Some parts of this publication contain **statements about the suitability of our products for certain areas of application**. These statements are based on our knowledge of typical requirements that are often placed on our products in the areas of application concerned. We nevertheless expressly point out **that such statements cannot be regarded as binding statements about the suitability of our products for a particular customer application**. As a rule, EPCOS is either unfamiliar with individual customer applications or less familiar with them than the customers themselves. For these reasons, it is always ultimately incumbent on the customer to check and decide whether an EPCOS product with the properties described in the product specification is suitable for use in a particular customer application.
2. We also point out that **in individual cases, a malfunction of passive electronic components or failure before the end of their usual service life cannot be completely ruled out in the current state of the art, even if they are operated as specified**. In customer applications requiring a very high level of operational safety and especially in customer applications in which the malfunction or failure of a passive electronic component could endanger human life or health (e.g. in accident prevention or life-saving systems), it must therefore be ensured by means of suitable design of the customer application or other action taken by the customer (e.g. installation of protective circuitry or redundancy) that no injury or damage is sustained by third parties in the event of malfunction or failure of a passive electronic component.
3. **The warnings, cautions and product-specific notes must be observed.**
4. In order to satisfy certain technical requirements, **some of the products described in this publication may contain substances subject to restrictions in certain jurisdictions (e.g. because they are classed as “hazardous”)**. Useful information on this will be found in our Material Data Sheets on the Internet (www.epcos.com/material). Should you have any more detailed questions, please contact our sales offices.
5. We constantly strive to improve our products. Consequently, **the products described in this publication may change from time to time**. The same is true of the corresponding product specifications. Please check therefore to what extent product descriptions and specifications contained in this publication are still applicable before or when you place an order.

We also **reserve the right to discontinue production and delivery of products**. Consequently, we cannot guarantee that all products named in this publication will always be available.
6. Unless otherwise agreed in individual contracts, **all orders are subject to the current version of the “General Terms of Delivery for Products and Services in the Electrical Industry” published by the German Electrical and Electronics Industry Association (ZVEI)**.
7. The trade names EPCOS, EPCOS-JONES, Baoke, CeraDiode, CSSP, MLSC, PhaseCap, PhaseMod, SIFI, SIKOREL, SilverCap, SIMID, SIOV, SIP5D, SIP5K, UltraCap, WindCap are **trademarks registered or pending** in Europe and in other countries. Further information will be found on the Internet at www.epcos.com/trademarks.