

THIS DRAWING IS A CONTROLLED DOCUMENT.

PART NUMBER	REV	FIRST USED
680414 -1	G	854400-1
680414 -2	G	565435-5
680414 -3	G	354500-1

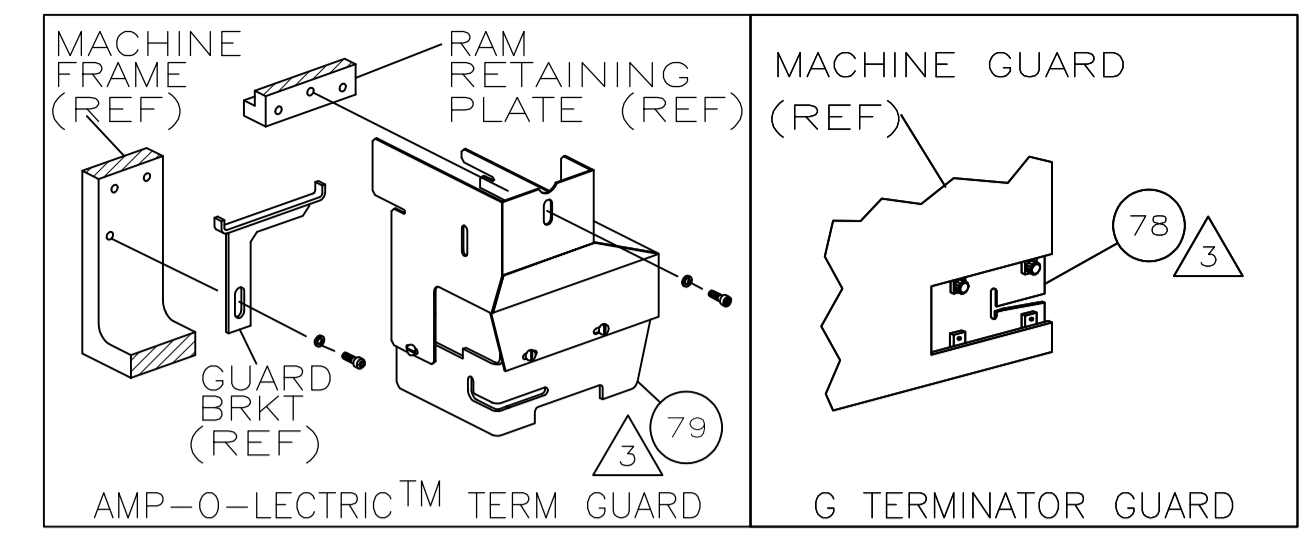

TERMINAL NAME: SPLICE		CRIMPING DATA	
TYCO TERM PN	STOCKO TERM PN	PAD LTR	CRIMP HEIGHT
41215	N/A	A	.063 ±.002 [1.6 ±0.05mm]
41459	N/A	B	.057 ±.002 [1.45 ±0.05mm]
1572807	RSB7735.001V-1.5	C	.050 ±.002 [1.27 ±0.05mm]
		D	NOT USED
WIRE STRIP LENGTH		TERM APPL SPEC	FEED
-		114-2088	.093
APPL INSTRUCTION		SET UP GAGE	LAYOUT
408-8039		458638-1	L1863

REV	DESCRIPTION	DATE
-1	LEADMAKER	
-2	BENCH MODEL K	
-3	BENCH MODEL G	

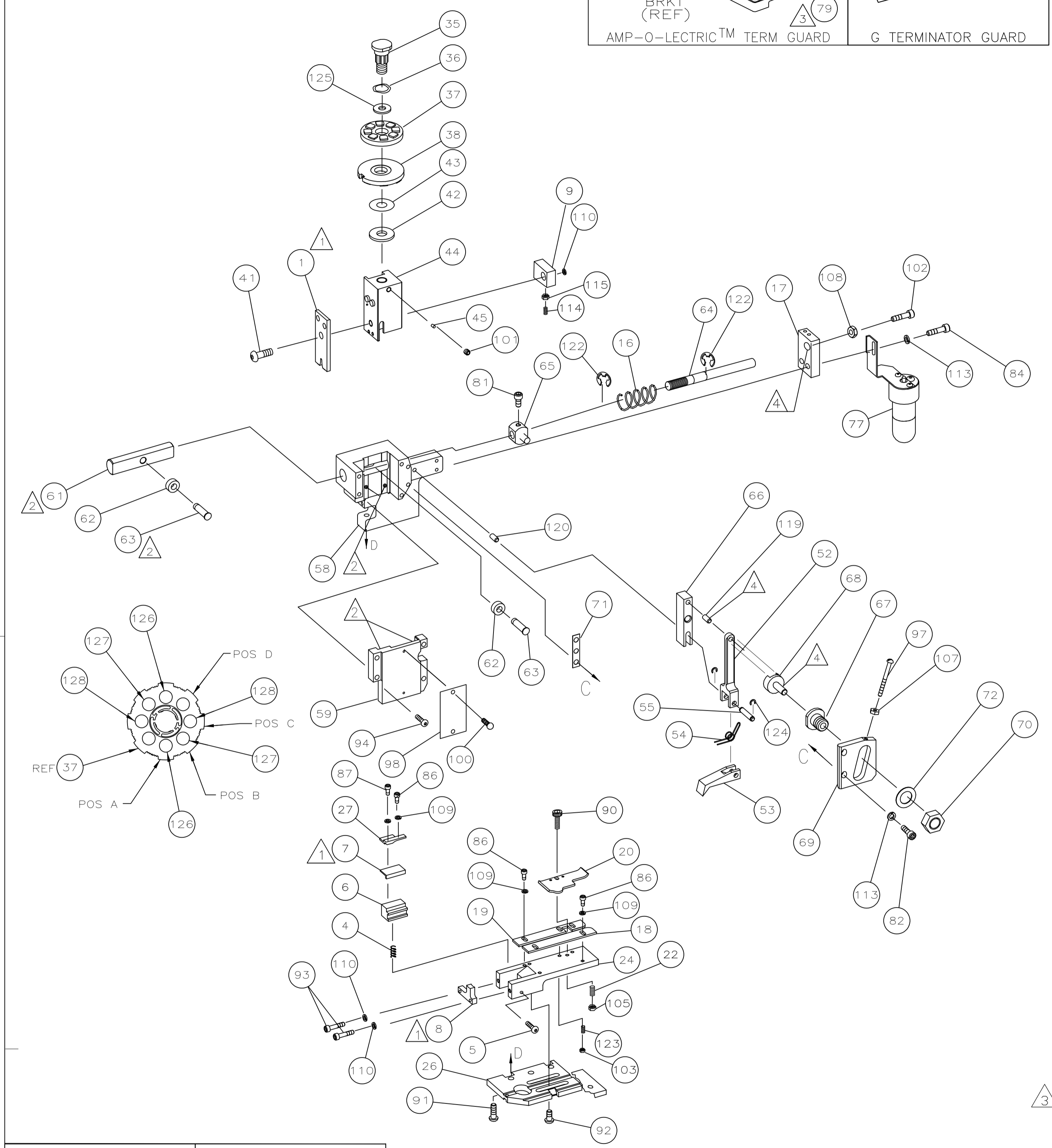

QTY	REQD	PER	ASSY	PART NO	DESCRIPTION	ITEM NO
2	2	2	-	6-354778-9	PIN, WIRE DISC (.2840)C	128
2	2	2	-	5-354778-5	PIN, WIRE DISC (.2770)B	127
2	2	2	-	4-354778-2	PIN, WIRE DISC (.2705)A	126
1	1	1	-	986950-1	WASHER, FLAT PRECISION	125
2	2	2	-	21045-3	RING,RET"C"(Ø.187)FD PIN	124
2	2	2	-	5-21061-5	SCR,SKT,SET CONE PT(8-32x.88)DRAG	123
2	2	2	-	1-21046-6	RING,RETAINING,EXT(5/16)FD ADJ ROD	122
1	1	1	-	217238-1	GENERAL INSTRUCTION PACKAGE	121
1	1	1	-	1-21030-7	PIN,DOWEL(Ø.187x1.50)HSG	120
1	1	1	-	1-21030-1	PIN,DOWEL(Ø.187x.50)LEVER	119
1	1	1	-	4088039	EF APPL INST 408-8039	117
2	2	2	-	21018-7	HEX NUT	115
1	1	1	-	3-21000-5	SKT,CAP,SCR	114
4	4	4	-	21024-5	WASHER,LOCK(NO.10)FEED	113
3	3	3	-	21024-4	WASHER,LOCK(NO.8)SHEAR BL	110
6	6	6	-	21024-3	WASHER,LOCK(NO.6)STRIP&SHEAR	109
1	1	1	-	22593-1	NUT,HEX(1/4-20)	108
1	1	1	-	21018-5	NUT,HEX(6-32)FD ADJ PL	107
1	1	1	-	21022-4	NUT,HEX SL(8-32)DRAG STUD	105
2	2	2	-	21018-6	NUT,HEX (8-32)DRAG	103
1	1	1	-	3-21081-3	SCR,SHC(1/4-20x1.25)MAGNET	102
1	1	1	-	21009-2	SCR,SKT SET(1/4-20x.25)RAM	101
2	2	2	-	21017-2	SCR,DRIVE(#2x.19)ID PLATE	100
1	1	1	-	1-21002-7	SCR,BHC(6-32x.38)CAM	99
1	1	1	-	461264-1	PLATE, IDENTIFICATION	98
1	1	1	-	6-23715-5	SCR,PAN HD(6-32x1.50)FEED ADJ	97
2	2	2	-	994991-5	SCR,OVAL HD(M4X12)COUNTER	96
4	4	4	-	2-21002-9	SCR,BHC(10-32x.75)HSG CAP	94
2	2	2	-	2-21000-7	SCR,SHC(8-32x.50)ANVIL	93
4	4	4	-	3-21002-3	SCR,BHC(1/4-20x.50)ST GD PL	92
3	3	3	-	2-22733-8	SCR,BHC(1/4-20x.62)BASE PL	91
2	2	2	-	21001-7	SCR,SHC(1/4-20x1.25)DRAG&RAM	90
1	1	1	-	2-21000-0	SCR,SHC(6-32x.50)STRIPPER&SHEAR	87
5	5	5	-	1-21000-9	SCR,SHC(6-32x.38)STRIP GUIDE	86
2	2	2	-	3-21000-7	SCR, SKT CAP(10-32x.75)FD GDE	84
1	1	1	-	3-21000-0	SCR, SKT 8-32X.88	83
2	2	2	-	3-21000-6	SCR,SKT CAP(10-32x.62)FD ADJ P	82
1	1	1	-	3-21000-4	SCR,SKT CAP(10-32x.38)PIVOT BL	81
2	2	2	-	3-21000-9	SCR,SKT CAP(10-32x1.00)SH PL	80
-	1	-	-	463924-1	GUARD, WINDOW	79
REF	-	-	-	679532-1	INSERT, GUARD	78
-	1	-	-	465184-9	LUBRICATOR ASSY	77
1	1	1	-	458109-1	WASHER, FLAT (SPECIAL)	72
1	1	1	-	690517-1	SPACER	71
-3	-2	-1	U/M			

QTY	REQD	PER	ASSY	PART NO	DESCRIPTION	ITEM NO
1	1	1	-	22594-8	NUT, HEX	70
1	1	1	-	240628-2	PLATE, ADJ	69
1	1	1	-	240626-1	SHAFT, PIVOT	68
1	1	1	-	240633-1	BUSHING	67
1	1	1	-	455680-1	LEVER, INTERMEDIATE	66
1	1	1	-	240629-1	BLOCK, PIVOT	65
1	1	1	-	1804311-1	SCR, ADJ	64
1	1	1	-	240659-3	PIN, CAM ROLLER	63
1	1	1	-	240658-1	CAM, ROLLER	62
1	1	1	-	454398-1	ROD, FEED	61
1	1	1	-	454220-1	CAP, RAM	59
1	1	1	-	453736-6	HOUSING	58
1	1	1	-	240624-1	PIN, FEED FINGER	55
1	1	1	-	691499-1	SPRING, FEED FINGER	54
1	1	1	-	240635-2	FINGER, FEED	53
1	1	1	-	240634-1	LEVER, TERMINAL	52
1	-	-	-	690602-6	CAM, PRE-FEED 1 5/8 ST	49
-	1	-	-	690602-5	CAM, PRE-FEED 1 1/8 ST	48
-	-	1	-	690501-4	CAM, POST-FEED 1 5/8 ST	47
1	1	1	-	690191-1	PLUG, NYLON	45
1	1	1	-	455674-1	RAM	44
1	1	1	-	690125-1	WASHER, LAMINATED	43
1	1	1	-	690124-4	WASHER, RAM	42
1	1	1	-	7-21002-9	BOLT, CRIMPER(5/16-24x1.00)	41
1	1	1	-	690223-1	INSULATION SPACER	38
1	1	1	-	354777-1	WIRE DISC, PLASTIC	37
1	1	1	-	22480-5	WASHER, SPRING	36
1	1	1	-	690212-1	POST, RAM	35
1	1	1	-	458412-1	PLATE, STRIP GUIDE	24
1	1	1	-	1-22282-9	SPRING, DRAG	22
1	1	1	-	458403-1	DRAG, STOCK	20
1	1	1	-	458406-2	GUIDE, STRIP (REAR)	19
1	1	1	-	458404-2	GUIDE, STRIP (FRONT)	18
1	1	1	-	1804305-2	GUIDE, FEED ROD	17
1	1	1	-	4-22284-9	SPRING, FEED RETURN	16
1	1	1	-	904181-1	HOLDER, DEPRESSOR	9
1	1	1	-	462320-4	ANVIL	8
1	1	1	-	458410-6	SHEAR	7
1	1	1	-	458409-5	HOLDER, SHEAR	6
1	1	1	-	690461-4	SCR, SHEAR STOP	5
1	1	1	-	6-22282-8	SPRING, SHEAR RETURN	4
1	1	1	-	4-456406-9	CRIMPER, WIRE	1

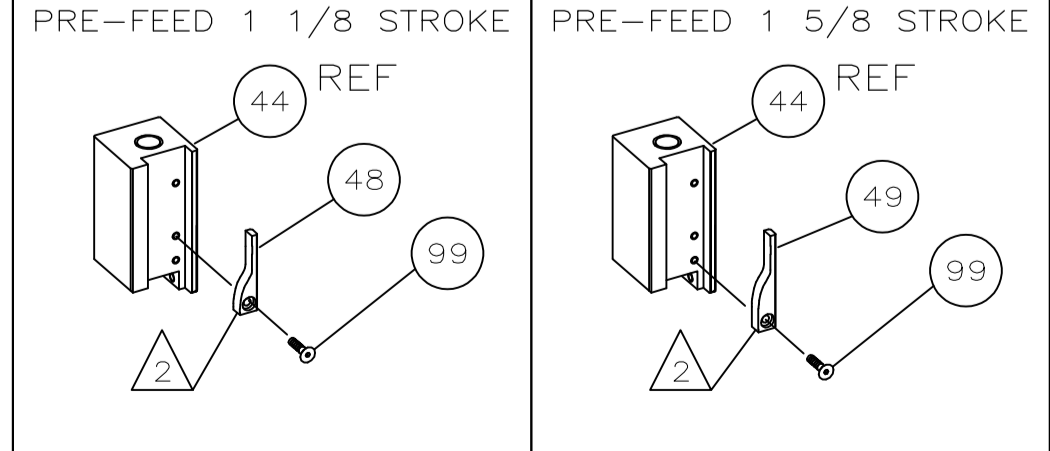

- 1 RECOMMENDED SPARE PARTS.
- 2 GREASE LIGHTLY.
- 3 GUARD MUST BE IN PLACE WHEN OPERATING APPLICATOR IN A BENCH MACHINE.
- 4 LUBRICATE DAILY USING NO. 20 MACHINE OIL.
- 5 CUSTOMER USING A SINGLE LEAD APPLICATION

LOC A	K TERMINATOR	G TERMINATOR
DIST 66	BENCH MACHINE	

3308-8 (5/11)

REV	DESCRIPTION	DATE	BY	CHKD
G	ECR-14-011516	7-2014	MY	GB
P	LTR	REVISION RECORD		

DIMENSIONS: INCHES	TOLERANCES UNLESS OTHERWISE SPECIFIED: 0 PLC ±.010 1 PLC ±.008 2 PLC ±.006 3 PLC ±.004 4 PLC ±.002	DATE: 7-2014	BY: MY	CHKD: GB	APVD: J.DODDS	NAME: J.DODDS	SCALE: -	SIZE: A1	DRAWING NO: 680414	SHEET: 1 of 1	REV: G
-----------------------	---	--------------	--------	----------	---------------	---------------	----------	----------	--------------------	---------------	--------

CUSTOMER ACCESSIBLE PRODUCTION DRAWING