

**NOTES:**  
**Mechanical:**  
 1. Housing material : High Temp. Polyester UL94V-0 , Color: Black  
 2. Contact material: Phosphor Bronze t=0.35mm  
 3. Contact plating: Contact area---Selective gold plating  
 Tails---Tin plated all over 50u" Nickel  
 4. Operating Life: 750 Cycles min.  
 5. PCB Retention Post-solder: 10 LBS min.  
**Electrical:**  
 1. Voltage Rating: 125VAC.  
 2. Current Rating: 1.5AMP.  
 3. Contact Resistance: 35mΩ max.  
 4. Insulation Resistance: 1000MΩ min. @ 500 VDC  
 5. Dielectric Strength: 1000 VAC 60Hz, 1 min.  
**Environmental:**  
 1. Storage: -40°C To +85°C  
 2. Operation: -40°C~+85°C  
 3. IR Reflow Soldering Temp: 255°C~265°C(5~10S)

Packing: 130pcs/Tape reel, 1300pcs/Carton

Order code: A-2004-2-X-LP/SMT

Contact plating:  
 1: Selective 15u" gold  
 2: Selective 30u" gold  
 3: Selective 50u" gold  
 4: Selective 6u" gold

PC Board Layout  
 Component Side Shown

**RoHS compliant**  
 Unit:mm

Scale	Free					Date	Name	Customer-No.
TOLERANCE						Drawn	27.05.2013	Amy
X.X	±0.20					Approved	22.04.2014	Amy
X.XX	±0.15							
X.XXX	±0.10							
DIM	TOL	①	Add tape reel packing on page 2	22.04.2014	Amy			
		②	Drawn	27.05.2013	Amy			
Angle	±5°	Id.	Modification	Date	Name	Drawing-No. <b>ASS 5696 CO</b> rev01 Replace SHEET 1 / 2		

Customer-No.	
ASSMANN WSW-No. <b>A-2004-2-X-LP/SMT</b>	
Drawing-No. <b>ASS 5696 CO</b> rev01	
Replace	SHEET 1 / 2

1

2

3

4

5

6

7

1 2 3 4 5 6 7

A

A

1.PRODUCT 1PCS

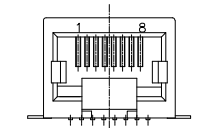
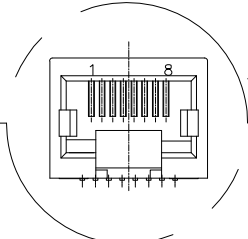

1.SIDE ENTRY SMT 8P8C JACK  
150 PCS/REEL  
1500PCS/CARTON

2.CARTON

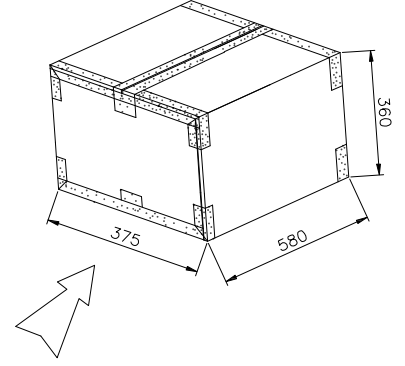
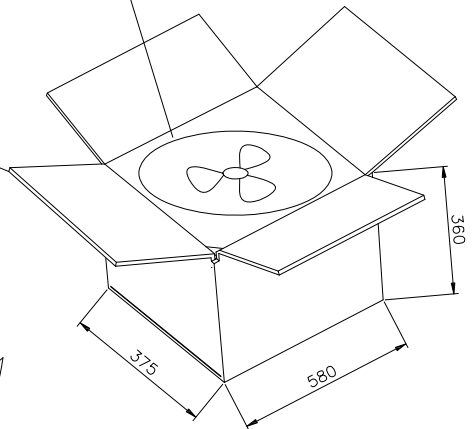

B

B

C

C

D

D

3.TAPE REEL

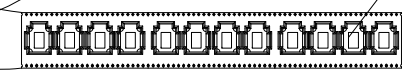
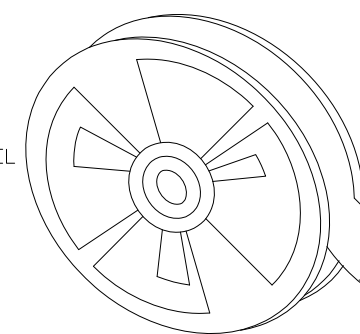

Keep each 5pcs blank  
on front and tail

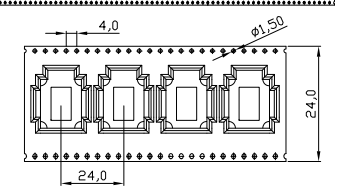

E

E

F

F

**RoHS compliant**  
Unit:mm

Scale	Free						Date	Name	Customer-No.	
TOLERANCE						Drawn	27.05.2013	Amy	ASSMANN WSW-No. A-2004-2-X-LP/SMT	
X.X	±0.20					Approved	22.04.2014	Amy		
X.XX	±0.15									
X.XXX	±0.10									
DIM	TOL	①	Add tape reel packing on page 2	22.04.2014	Amy				Drawing-No.	
		②	Drawn	27.05.2013	Amy				ASS 5696 CO	rev01
Angle	±5°	Id.	Modification	Date	Name				Replace	SHEET 2 / 2

G

G

H

H

1 2 3 4 5 6 7