

THIS DRAWING IS UNPUBLISHED. RELEASED FOR PUBLICATION ,19 .
 © COPYRIGHT 19 BY AMP INCORPORATED. ALL RIGHTS RESERVED.

| LOC | DIST | REVISIONS | | | |
|-----|------|-------------|--------------------------|---------|-------|
| P | LTR | DESCRIPTION | DATE | DWN | APVD |
| G | 14 | C | REDRAWN PER 0720-0470-95 | 23JAN95 | LO ME |

| | | |
|--------------------------------|--------------------------------|--------------------------------|
| AMP WIRE RANGE | E13288 | LR7189 Certified |
| 22-16 AWG SOLID OR STRANDED | 22-16 AWG SOLID OR STRANDED | 22-16 AWG SOLID OR STRANDED |

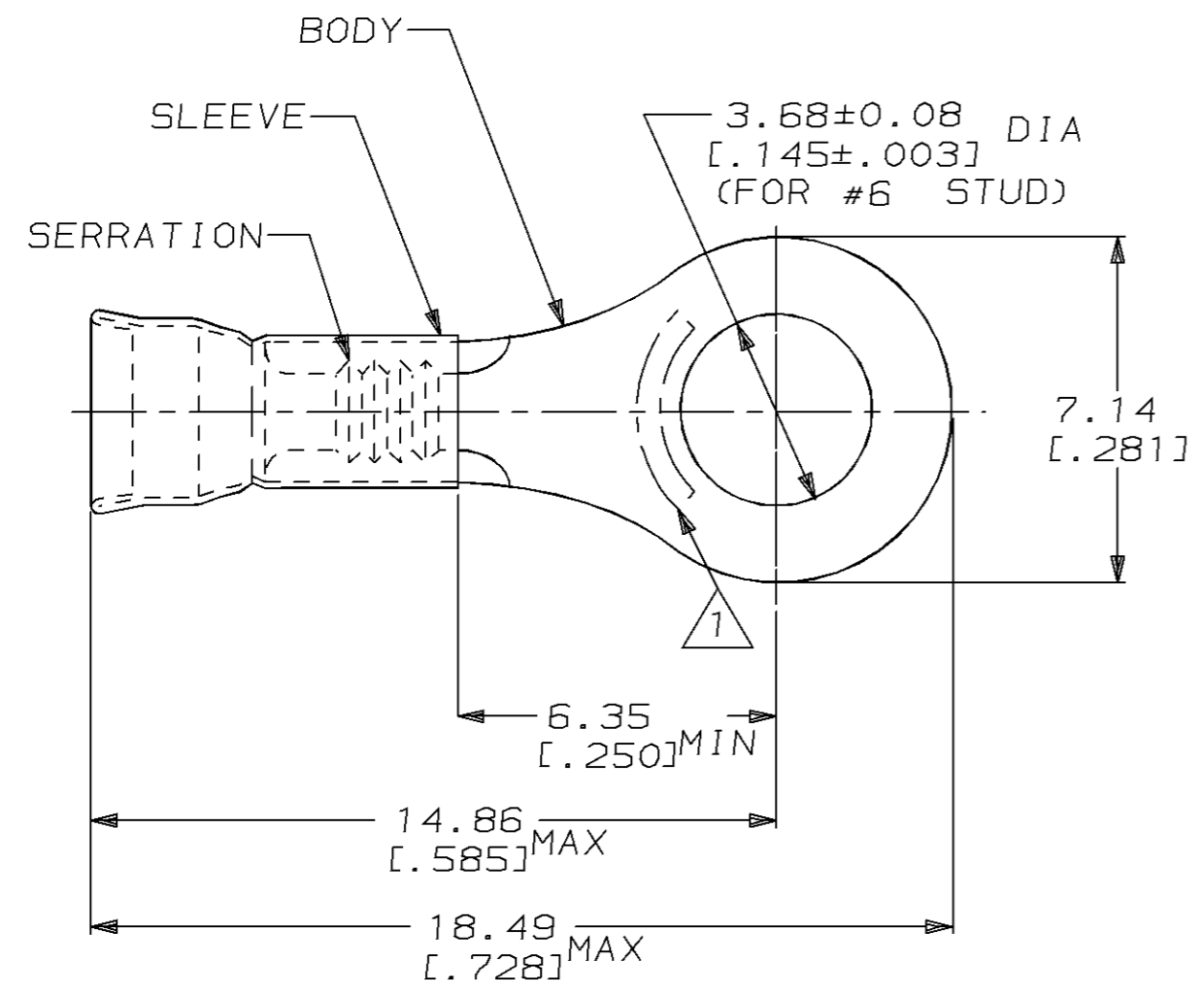

- 1. STAMP AMP 22-18* APPROX AS SHOWN
22-16 TERMINALS ARE STAMPED 22-18 IN
ACCORDANCE WITH MILITARY SPEC MIL-T-7928
COMMERCIAL WIRE RANGE IS 22-16
- 2. WIRE INSUL DIA, 2.03-3.18 [.080-.125]
- 3. TONGUE MATL THK, 0.79±0.05 [.031±.002]

| | | |
|------|---------------|-----------|
| 5000 | ON TAPE, REEL | 2-31269-1 |
| 1000 | LOOSE PIECE | 31269 |
| QTY | PACKAGE TYPE | PART NO |

| | | | | | | |
|--|--|---|--|------------------------|--|--|
| AMP INCORPORATED CUSTOMER SERVICE SYSTEM | | MAX RECOMMENDED OPERATING TEMPERATURE: 170°C [338°F] | THIS DRAWING IS A CONTROLLED DOCUMENT FOR AMP INCORPORATED. IT IS SUBJECT TO CHANGE AND THE CONTROLLING ENGINEERING ORGANIZATION SHOULD BE CONTACTED FOR THE LATEST REVISION. | | DWN L OLMEDA 23JAN95 | AMP AMP Incorporated Harrisburg, PA 17105-3608 |
| FOR ADDITIONAL PRODUCT INFORMATION OR COPIES OF DRAWINGS AND TECHNICAL DOCUMENTS | PRODUCT INFORMATION CENTER 1-800-522-6752 | | VOLTAGE RATING: - | DIMENSIONS: mm [in] | TOLERANCES UNLESS OTHERWISE SPECIFIED: | |
| FOR APPLICATION TOOLING INFORMATION | TOOLING ASSISTANCE CENTER 1-800-722-1111 | CIRCULAR MIL AREA: 0.26mm ² -1.65mm ² [509-3260] | | 0 PLC ±- | APVD S BORTNER 23JAN95 | NAME TERMINAL, RING, DIAMOND GRIP, WIRE SIZE, 22-16 AWG |
| FOR ORDER ENTRY | 1-800-526-5142 | MATERIAL BODY, CU, SLV, CU PER ASTM B152 | | 1 PLC ±- | 2 PLC ±0.20 [.008] | PRODUCT SPEC UL486A |
| | | | FINISH TIN PLATE PER MIL-T-10727 | 3 PLC ±- | APPLICATION SPEC - | CAGE CODE 00779 |
| | | | | 4 PLC ±- | WEIGHT - | DRAWING NO C-31269 |
| | | | | ANGLES ±- | CUSTOMER DRAWING | SCALE 6:1 |
| | | | | | | SHEET 1 OF 1 |
| | | | | | | REV C |