

THIS DRAWING IS UNPUBLISHED. RELEASED FOR PUBLICATION ,19 .  
 © COPYRIGHT 19 BY AMP INCORPORATED. ALL INTERNATIONAL RIGHTS RESERVED.

LOC	DIST	P	F	ZONE	LTR	DESCRIPTION	DATE	APPD
BD	36				0	RELEASED	10/28/92	-
					01	ADDED -6 NPR 4978, WAS 93-4883-008-2	11/05/93	TC
					A	REV PER EC 0020-1033-95	27 NOV 95	MM
					B	REV PER EC 061C-81-99	01 JUL 99	GS

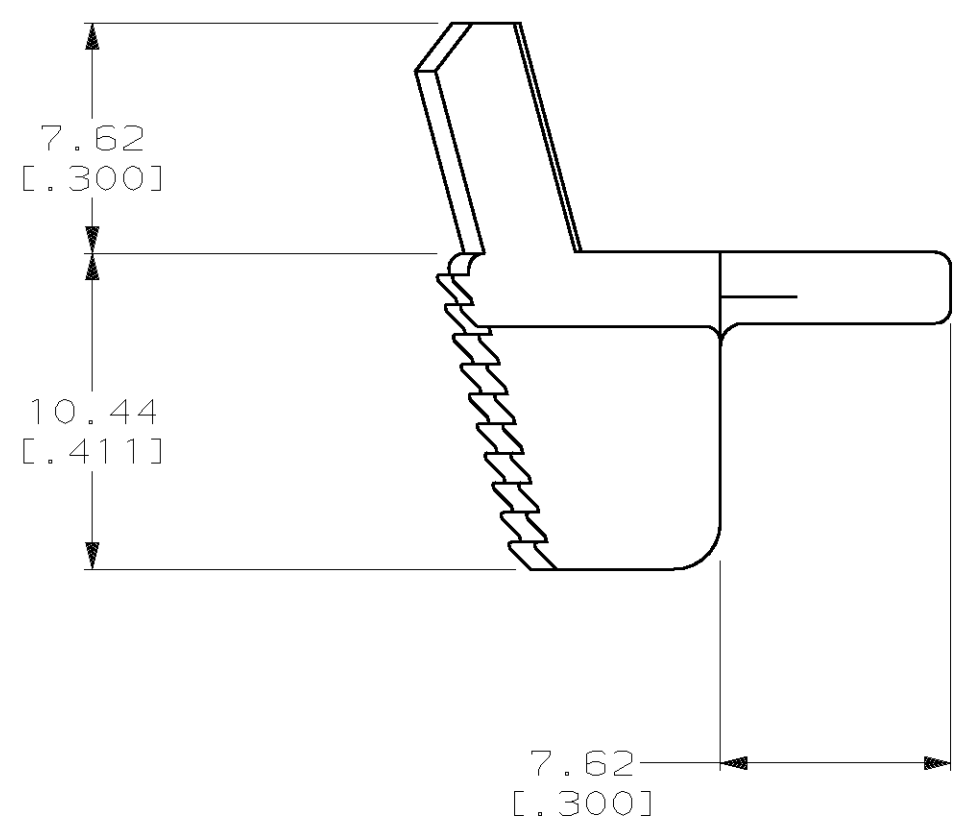
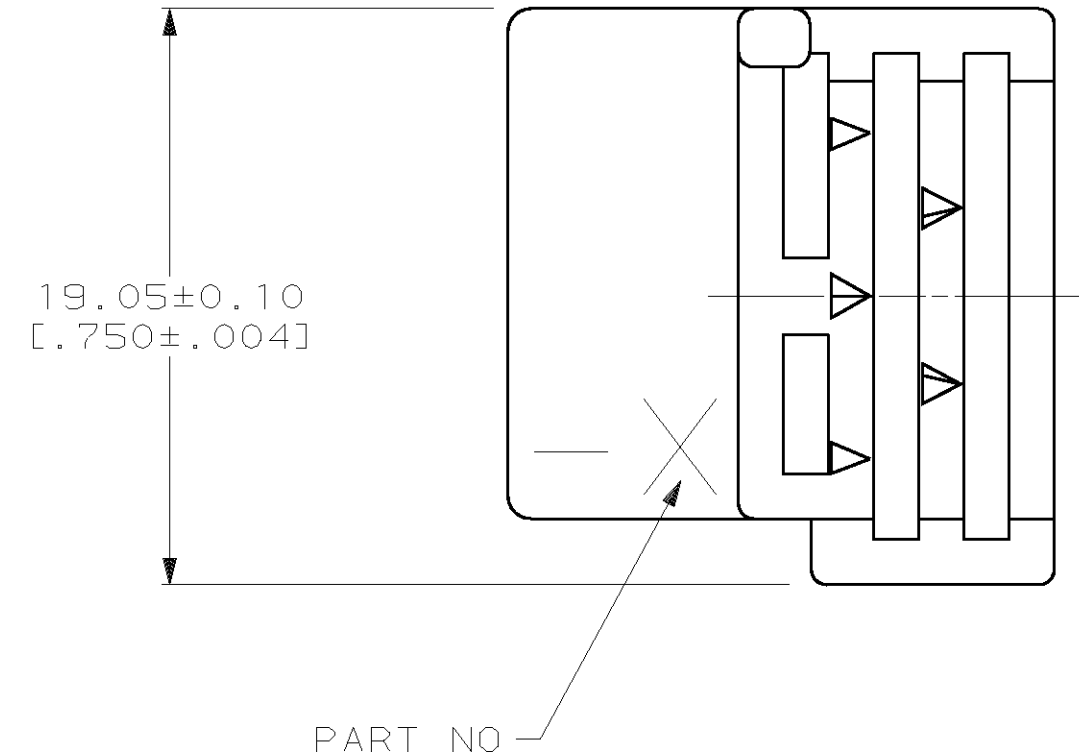
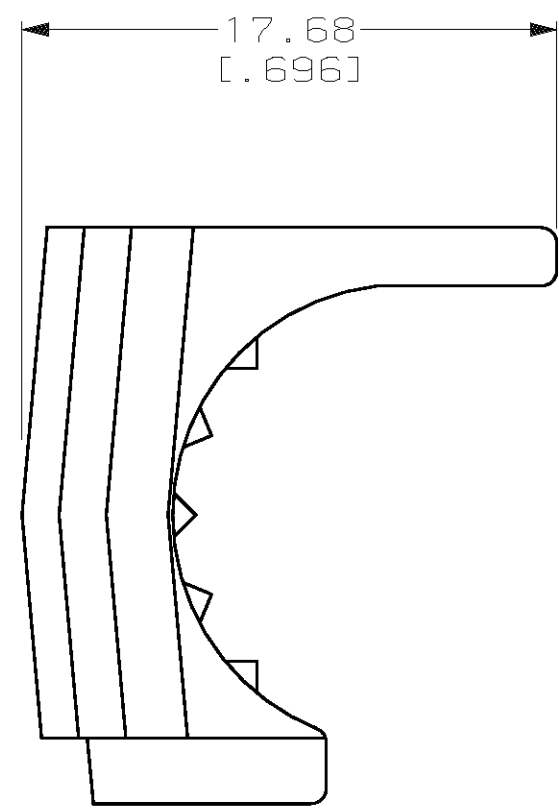

CABLE DIAMETER	PART NO
3.81-7.62 [0.150-.300]	213621-6
7.62-10.16 [0.300-.400]	213621-4
10.16-15.24 [0.400-.600]	213621-3

1 5.08µm [0.000200] MIN NICKEL OVER 5.08µm [0.000200] MIN COPPER.

DO NOT SCALE PRINT. UNLESS SPECIFIED DIMENSIONS IN mm [INCHES] TOLERANCES ON : 2 PLC DEC ± 0.13 [0.005] 3 PLC DEC ± - ANGLES ± -	DR 10/28/92 D.GELTZ CHK 10-28-92 R.STONE APPD 10-29-92 R.S.KLINE	AMP Incorporated Harrisburg, PA 17105-3608	
MATERIAL ZINC	APPD 10-29-92 R.S.KLINE PRODUCT SPEC -	NAME CABLE CLAMP, M SERIES	
FINISH 1	APPLICATION SPEC -	SIZE C	CAGE CODE 00779
	WEIGHT -	SCALE 4:1	DRAWING NO C=213621
			SHEET 1 OF 1

THIS DRAWING IS A CONTROLLED DOCUMENT FOR AMP INCORPORATED. IT IS SUBJECT TO CHANGE AND THE CONTROLLING ENGINEERING ORGANIZATION SHOULD BE CONTACTED FOR THE LATEST REVISION.