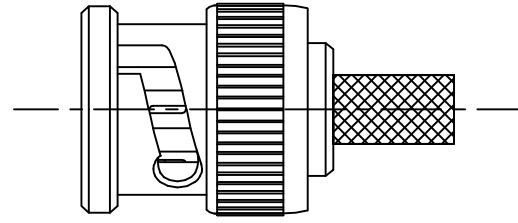
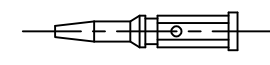
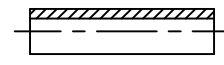
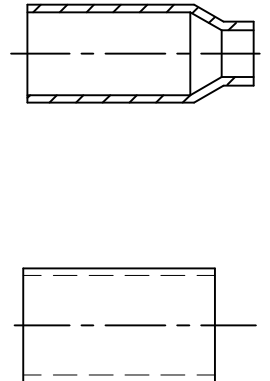

THIS DRAWING IS UNPUBLISHED. RELEASED FOR PUBLICATION DEC ,2004.
 © COPYRIGHT 2004 By - ALL RIGHTS RESERVED.

LOC		DIST		REVISIONS			
P	LTR	DESCRIPTION	DATE	DWN	APVD		
-	-	SEE SHEET 1	-	-	-		

COMPONENTS

MAIN BODY (ITEM 1,3,4,6,7 & 8)	CENTRE CONTACT (ITEM 2)	PUSHER SLEEVE (ITEM 9)	CRIMP FERRULES (ITEM 5 & 10)
			

ASSEMBLY INSTRUCTION

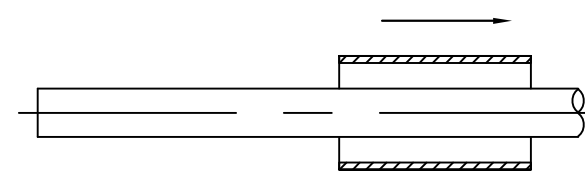
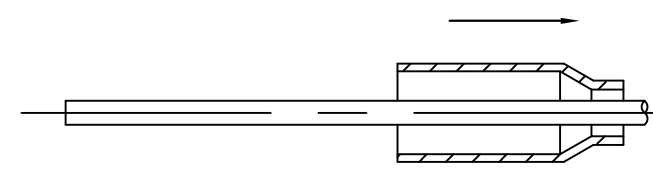
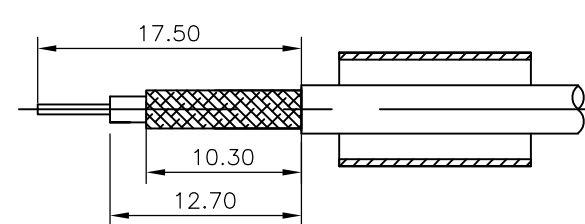
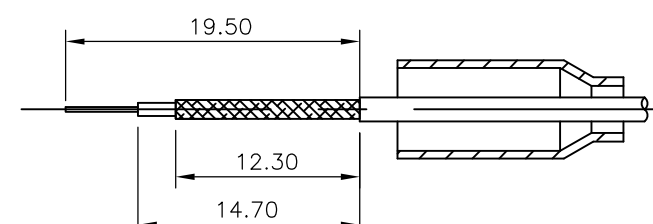
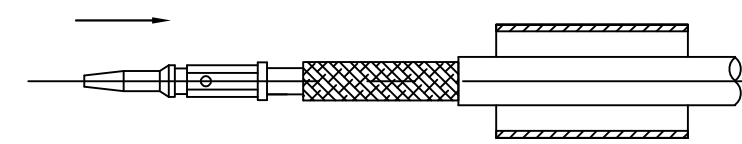
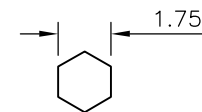
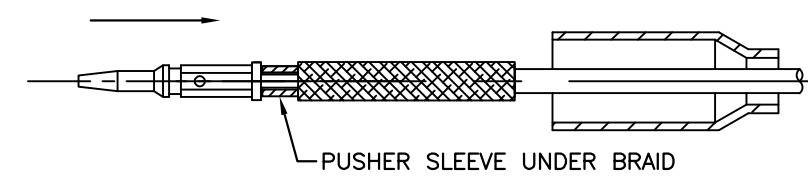
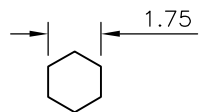
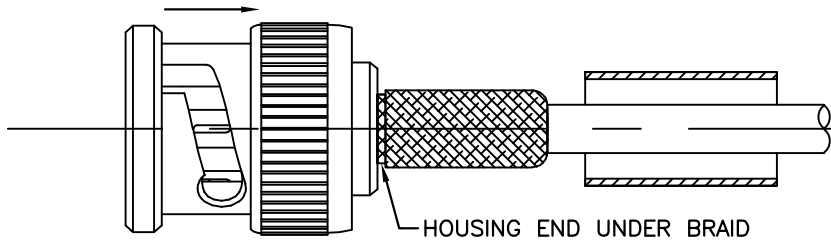
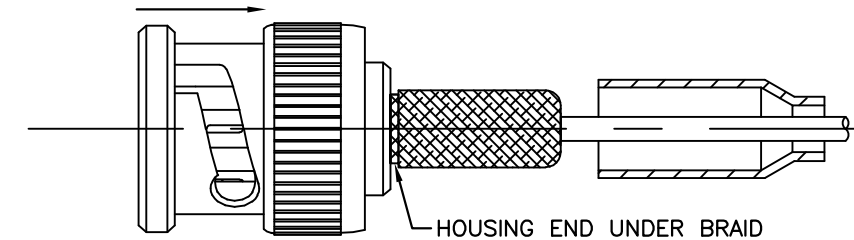
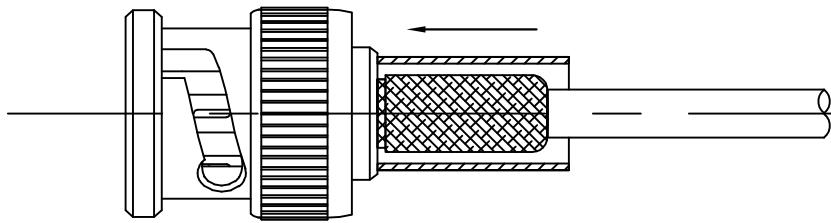
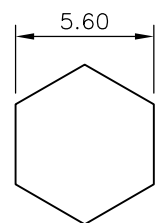
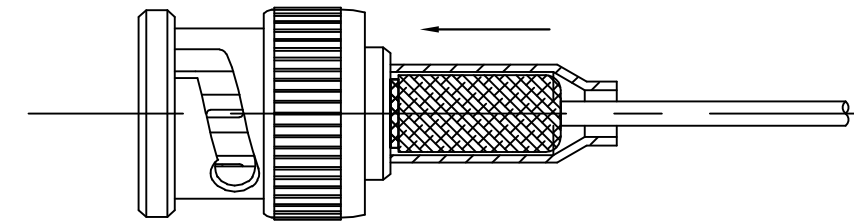
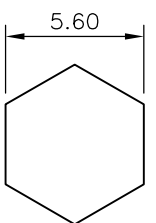
CABLES: RG58C/U, 141A/U, 303/U, URM43, 76, BELDEN 9907, KX15	CABLES: RG174A/U, 188A/U, 316/U, URM95, KX3B, KX22A, UTP CAROL CABLE #C6348A
<p>STEP 1</p> <p>1. SLIDE METAL CRIMP FERRULE OVER CABLE</p> 	<p>STEP 1</p> <p>1. SLIDE METAL CRIMP FERRULE OVER CABLE</p> 
<p>STEP 2</p> <p>1. STRIP CABLE TO DIMENSIONS AS SHOWN</p> 	<p>STEP 2</p> <p>1. STRIP CABLE TO DIMENSIONS AS SHOWN</p> 
<p>STEP 3</p> <p>1. FIT CONTACT OVER CENTRE CONDUCTOR TO BUTT AGAINST DIELECTRIC. 2. CRIMP USING TOOL AS NOTES ON PAGE 1.</p>  <p>RECOMMENDED CENTRE CONTACT A/F HEX</p> 	<p>STEP 3</p> <p>1. SLIDE ITEM 9 PUSHER SLEEVE OVER DIELECTRIC BEFORE FITTING THE CONTACT. NO PUSHER SLEEVE IS NEEDED FOR 5-1634500-4 & 5-1634500-5. 2. FIT CONTACT OVER CENTRE CONDUCTOR TO BUTT AGAINST DIELECTRIC. 3. CRIMP USING TOOL AS NOTES ON PAGE 1.</p>  <p>RECOMMENDED CENTRE CONTACT A/F HEX</p> 
<p>STEP 4</p> <p>1. PRESS SUB-ASSEMBLY INTO BODY, UNTIL CONTACT IS FULLY LOCATED BY AN AUDIBLE CLICK. 2. ENSURE THAT KNURLED HOUSING INSERTS BETWEEN THE DIELECTRIC AND CABLE BRAID.</p> 	<p>STEP 4</p> <p>1. PRESS SUB-ASSEMBLY INTO BODY, UNTIL CONTACT IS FULLY LOCATED BY AN AUDIBLE CLICK. 2. ENSURE THAT KNURLED HOUSING INSERTS BETWEEN THE PUSHER SLEEVE AND CABLE BRAID.</p> 
<p>STEP 5</p> <p>1. SLIDE CRIMP FERRULE ALONG THE CABLE UNTIL IT BUTTS AGAINST THE HOUSING BODY. 2. CRIMP USING TOOL AS NOTED ON PAGE 1. 3. CRIMP DIMENSION AS SHOWN.</p>  <p>RECOMMENDED CRIMP SLEEVE A/F HEX</p> 	<p>STEP 5</p> <p>1. SLIDE CRIMP FERRULE ALONG THE CABLE UNTIL IT BUTTS AGAINST THE BODY HOUSING. 2. CRIMP USING TOOL AS NOTED ON PAGE 1. 3. CRIMP DIMENSION AS SHOWN.</p>  <p>RECOMMENDED CRIMP SLEEVE A/F HEX</p> 

THIS DRAWING IS A CONTROLLED DOCUMENT.

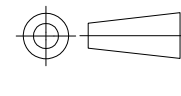
DIMENSIONS: MM	TOLERANCES UNLESS OTHERWISE SPECIFIED	DWN RITA ZUO 19 Feb 09	 TE Connectivity													
	<table border="1"> <tr><td>0 PLC</td><td>±</td></tr> <tr><td>1 PLC</td><td>±</td></tr> <tr><td>2 PLC</td><td>±</td></tr> <tr><td>3 PLC</td><td>±</td></tr> <tr><td>4 PLC</td><td>±</td></tr> <tr><td>ANGLES</td><td>±</td></tr> </table>	0 PLC		±	1 PLC	±	2 PLC	±	3 PLC	±	4 PLC	±	ANGLES	±	CHK ANSON MA 19 Feb 09	NAME
		0 PLC		±												
		1 PLC		±												
2 PLC	±															
3 PLC	±															
4 PLC	±															
ANGLES	±															
MATERIAL SEE TABLE	FINISH SEE TABLE	APVD BOB ZHAO 19 Feb 09	BNC STRAIGHT PLUG HEX CRIMP 50 OHM													
		PRODUCT SPEC 108-112000	RESTRICTED TO													
		APPLICATION SPEC SHEET 2	SIZE A2 CAGE CODE 00779 DRAWING NO C=1634500													
		WEIGHT -	SCALE NTS SHEET 2 of 2 REV G													
		CUSTOMER DRAWING														