

THIS DRAWING IS UNPUBLISHED. RELEASED FOR PUBLICATION  
 © COPYRIGHT 19 BY AMP INCORPORATED. ALL INTERNATIONAL RIGHTS RESERVED.

LOC	DIST	P	F	ZONE	LTR	DESCRIPTION	DATE	APPD
G	14				C	REV / 0610-0026-99	12FEB99	MLE SU

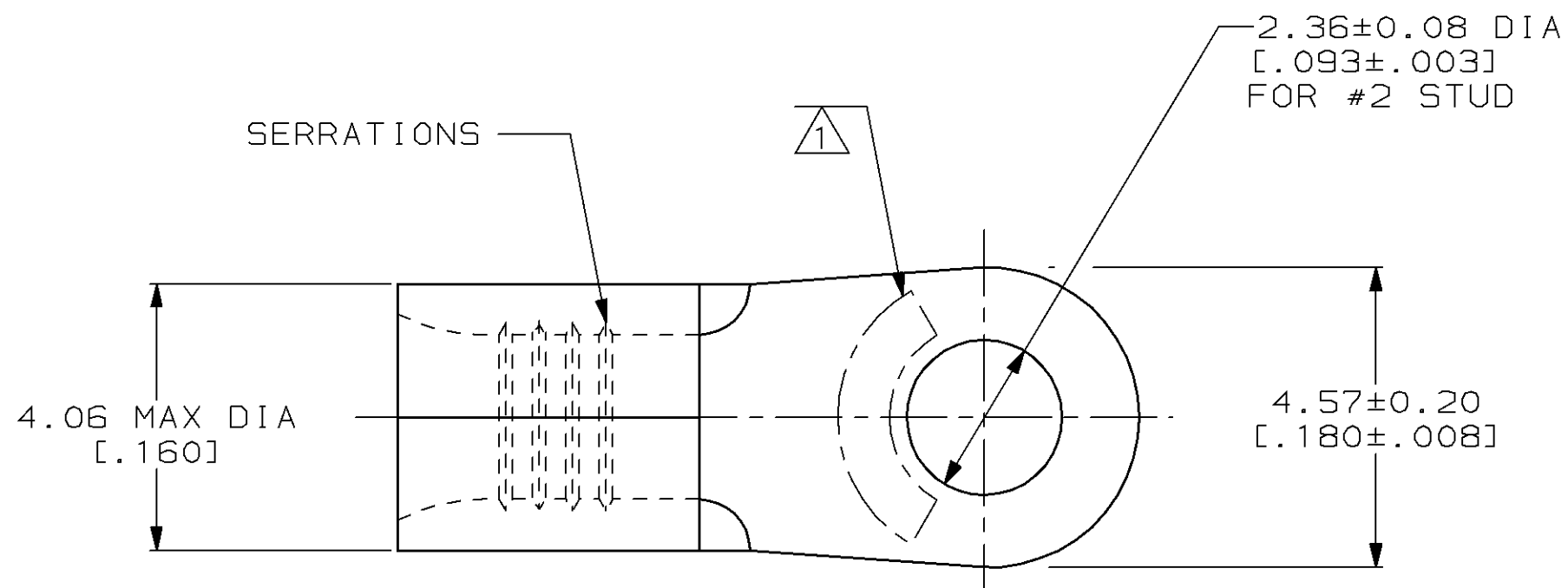

<b>AMP</b> WIRE RANGE	<b>UL</b> E13288 Listed
16-14 AWG STRANDED	16-14 AWG STRANDED

<b>CS</b> LR7189 Certified	MILITARY P/N AND CLASS
NOT CERTIFIED	NOT APPLICABLE

① STAMP AMP 16-14\* APPROX AS SHOWN

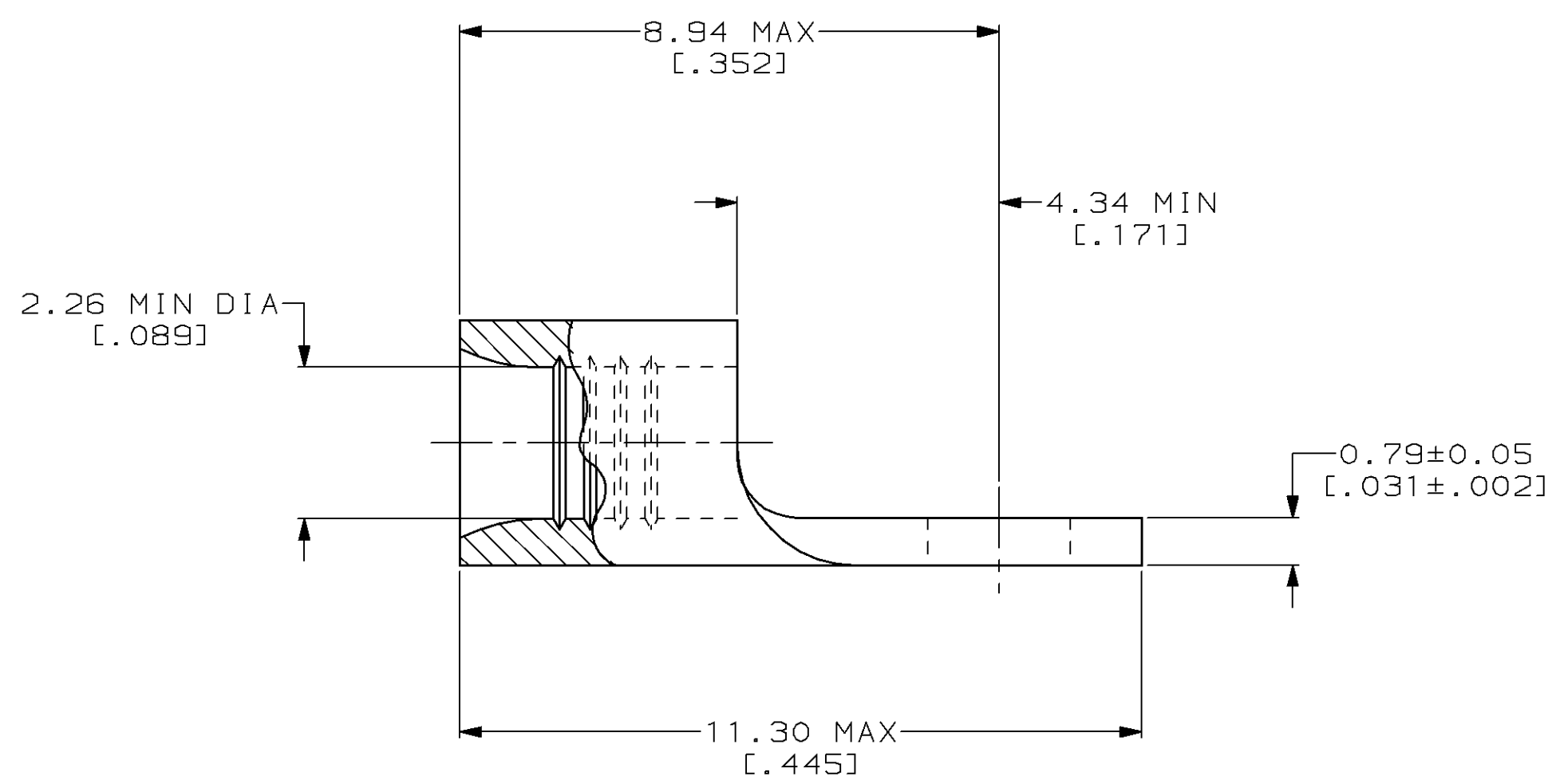

326854

AMP INCORPORATED CUSTOMER SERVICE SYSTEMS		MAX RECOMMENDED OPERATING TEMPERATURE: 170°C MAX		DO NOT SCALE PRINT. UNLESS SPECIFIED DIMENSIONS IN mm [INCHES] TOLERANCES ON: 2 PLC DEC ± - 3 PLC DEC ± - ANGLES ± -		DR 2-4-93 TA BRINKMAN		326854 PART NO	
FOR ADDITIONAL PRODUCT INFORMATION OR COPIES OF DRAWINGS AND TECHNICAL DOCUMENTS		PRODUCT INFORMATION CENTER 1-800-522-6752		VOLTAGE RATING: NOT APPLICABLE		MATERIAL COPPER PER ASTM B-152 ANNEALED		AMP Incorporated Harrisburg, PA 17105-3608	
FOR APPLICATION TOOLING INFORMATION		TOOLING ASSISTANCE CENTER 1-800-722-1111		WIRE CROSS SECTIONAL AREA RANGE: 1.04-2.62mm <sup>2</sup> [2,050-5,180] CIR MILS STRANDED		FINISH TIN PLATE 0.00254 [0.000100] MIN THK PER ASTM B-545		NAME TERMINAL, RING TONGUE, BUDGET	
FOR ORDER ENTRY		1-800-526-5142		THIS DRAWING IS A CONTROLLED DOCUMENT FOR AMP INCORPORATED. IT IS SUBJECT TO CHANGE AND THE CONTROLLING ENGINEERING ORGANIZATION SHOULD BE CONTACTED FOR THE LATEST REVISION.		APPD 2-4-93 DA PATTERSON		APPD 2-4-93 DE MILLER	
						PRODUCT SPEC -		APPLICATION SPEC -	
						WEIGHT -		SIZE C 00779	
								DRAWING NO G=326854	
								SCALE 10:1	
								SHEET 1 OF 1	